

DEUTSCH

Lieber Kunde, liebe Kundin,

wir freuen uns, dass Sie sich für ein Produkt der Marke "RICCO" entschieden haben.

Manchmal trotz aller Bemühungen unsererseits Ihnen ein qualitativ hochwertiges Produkt zu liefern, kann es vorkommen, dass einmal ein Zubehörteil fehlt oder ein Teil während des Transports beschädigt wird. **In diesem Fall senden Sie den Artikel bitte nicht zurück**, sondern fordern Sie einfach Ersatz für das fehlende bzw. beschädigte Teil bei unserer Kunden-Hotline an. Kontaktdaten von unserer **Kunden-Hotline** sind unten aufgeführt.

Bitte nennen Sie bei der Kontaktaufnahme die Artikeldaten (unten aufgeführt), Artikelfarbe sowie die benötigten Teilnummern (inkl. benötigter Stückzahl), wie sie in dieser Anleitung unter dem Punkt "Lieferumfang" angegeben sind.

Halten Sie ebenfalls Ihre **Bestellnummer / Order-ID** für unsere Kunden-Hotline bereit. Wir werden Ihre Anfrage umgehend bearbeiten!

ENGLISH

Dear customer,

we are pleased that you have decided for a product of the brand "RICCO".

Sometimes, despite our efforts to provide you with a high-quality product, it may happen that an accessory is missing or a part is damaged during transport. **Please do not return the item in such a case**, simply request replacement for the missing or damaged part at our customer hotline. Contact details from our **customer hotline** are listed below.

When contacting us, **please mention the article data (listed on top), article color as well as the required spare part numbers (including the required quantity of items)**, as indicated in the "Scope of delivery" section of this manual.

Please keep ready your **order number / order ID** for our customer hotline. We will process your request immediately!

FRANÇAIS

Cher client, chère cliente,

Nous sommes heureux que vous ayez choisi un produit de la marque "RICCO".

Parfois, malgré tous nos efforts pour vous livrer un produit de grande qualité, il peut arriver qu'un accessoire manque ou une pièce soit endommagée pendant le transport. **Dans ce cas, ne renvoyez pas l'article**, demandez tout simplement le remplacement de la pièce manquante ou endommagée à notre **hotline client** dont les coordonnées sont listées ci-dessous.

Lors de votre prise de contact, veuillez indiquer les références (numérotées ci-dessous), la couleur de l'article et les numéros de pièces nécessaires (ceci incluant le nombre de pièces nécessaires) tels qu'indiqués au point "Contenu de la livraison" de cette notice.

Préparez également votre **numéro de commande / ID de commande** pour notre hotline client. Nous traiterons votre demande dans les plus brefs délais!

ESPAÑOL

Estimados clientes,

Nos alegramos de que haya escogido la marca "RICCO".

A veces, a pesar de todos los esfuerzos que realizamos por suministrarle un producto de buena calidad, puede suceder que alguna vez falte un accesorio o que alguna pieza se rompa durante el transporte. **En tal caso, le rogamos que no nos envíe el artículo da vuelta**; sino que simplemente pida el repuesto para la pieza que falte o esté deteriorada a nuestra línea de atención **directa al cliente**. Puede encontrar los datos de contacto de nuestra línea de atención directa en la página derecha.

Le rogamos que cuando se ponga en contacto con nosotros mencione los datos de los artículos (enumeradas a continuación), el color del artículo y los números de piezas necesarios (incl. el número de piezas que necesita) tal y como se indica en las presentes instrucciones bajo el punto "Volumen de entrega".

Igualmente, tenga preparado su **número de pedido / ID del pedido** para nuestra línea de atención directa. ¡Procesaremos su solicitud de inmediato!

ITALIANO

Gentile cliente,

Siamo lieti che abbia scelto un prodotto del marchio "RICCO".

Nonostante i nostri sforzi per fornirvi un prodotto di alta qualità, talvolta può capitare che manchi un accessorio oppure che un componente si danneggi durante il trasporto. **In questi casi non restituite il prodotto**, ma richiedete la sostituzione del pezzo mancante o danneggiato chiamando semplicemente il nostro servizio di **assistenza clienti**. I dati di contatto della linea dedicata sono riportati a destra.

Durante la chiamata si prega di fornire i dati rilevanti (vedi sotto), il colore e il numero di identificazione (incl. le quantità) dell'articolo richiesto come riportati nelle presenti istruzioni d'uso al punto "Volumi di fornitura".

Tenga a sempre a portata di mano il suo **numero d'ordine / Order-ID** per poterlo fornire su richiesta al nostro servizio assistenza clienti. Elaboreremo la sua richiesta il più presto possibile!

WM083E-Mail: support@ricco.de
www.ricco.euE.N.Z. Engineering GmbH
Salzmatten 6
79341 Kenzingen
(Germany)

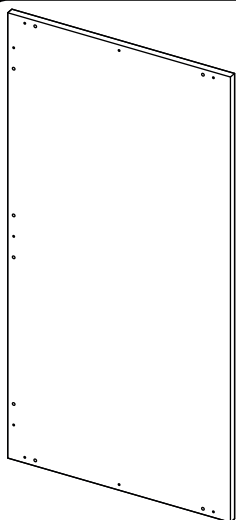
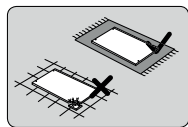
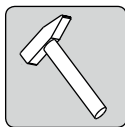
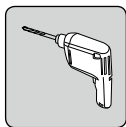
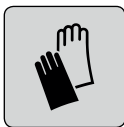

1x A

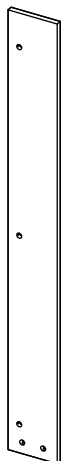

1x B

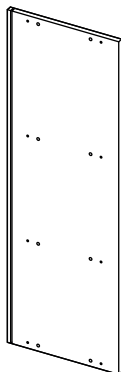

1x C

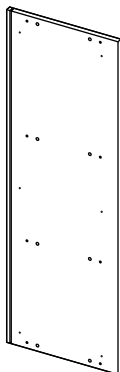

1x D

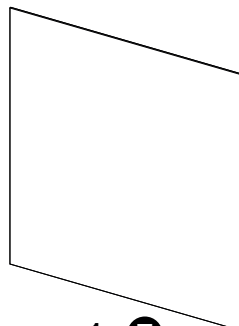

1x E

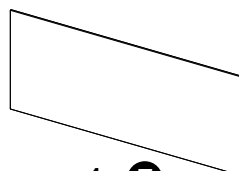

1x F

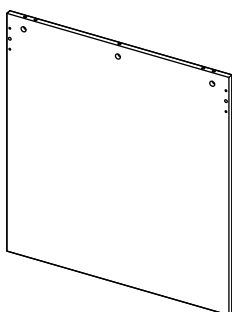

1x G

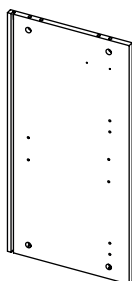

1x H

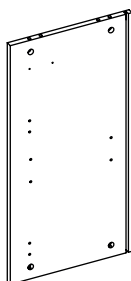

1x I

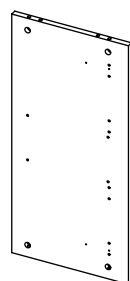

1x J

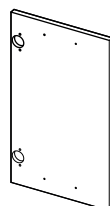

1x K

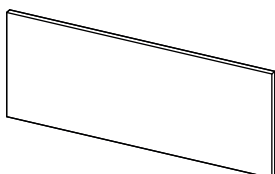

1x L

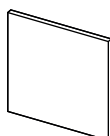

1x M



1x N



1x O



1x P

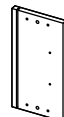

1x Q

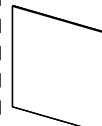

1x R

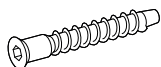

2 x **M104**

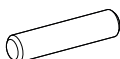

23 x **M202**



24 x **M206**



24 x **M111**



8 x **M224**

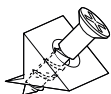

6 x **M216**



2 x **M211**



10 x **M212**



38 x **M221**
ø 14mm



20 x **M222**
ø 18mm



2 x **M226**

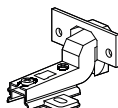

2 x **M204**

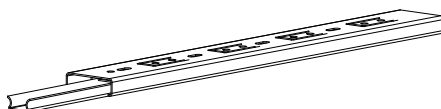

2 x **M201**



4 x **M102**
3x16mm



24 x **M101**
3,5x16mm

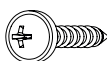

3 x **M108**
4,2x16mm



4 x **M103**
4x35mm

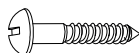

4 x **M110**
4x30mm



4 x **M116**
6,3x13mm

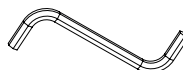

1 x **M223**

DE SICHERHEITSHINWEISE ACHTUNG: Lesen Sie die gesamte Bedienungsanleitung durch, bevor Sie mit der Montage beginnen.



BEACHTEN SIE UNBEDINGT FOLGENDE SICHERHEITSHINWEISE.
FÜR SCHÄDEN, DIE DURCH NICHTBEACHTUNG ENTSTEHEN, HAFET DER HERSTELLER NICHT.

VOR DEM GEBRAUCH

- Vor dem ersten Gebrauch den Artikel bitte gut auslüften.

BESTIMMUNGSGEMÄßER GEBRAUCH

- Dieser Artikel ist ausschließlich für den Innenbereich geeignet.
- Setzen Sie das Produkt nicht der Sonne oder Feuchtigkeit aus, da sonst ein Verziehen des Materials oder Verblässen der Farbe nicht ausgeschlossen werden kann.
- Vermeiden Sie das Berühren des Möbelsstückes mit spitzen oder scharfen Gegenständen um die Oberflächen nicht zu beschädigen.
- Kleine Kinder sollten bei Benutzung stets unter der elterlichen Aufsicht stehen.

ERSTICKUNGS-/VERLETZUNGSGEFAHR!

- Lassen Sie Kinder nicht mit der Verpackung spielen. Sie könnten an der Folie ersticken oder sich an der Umverpackung verletzen.
- Verwenden Sie den Artikel nicht als Leiter- oder Trittschutz, Unterstellbock, Turngerät für Kinder o. Ä. Er könnte umkippen und Verletzungen verursachen.
- Achten Sie bei der Benutzung des Möbelsstückes auf sicheren Stand! Es besteht ansonsten Kippgefahr.

BESCHÄDIGUNGSGEFAHR!

- Gehen Sie bei der Montage des Artikels sorgfältig vor und halten Sie sich an die Montageanleitung.
- Der Artikel darf nur von fachkundigen Personen montiert werden.

UMWELTHINWEIS

- Entsorgen Sie die Verpackung bzw. das Produkt nach Abnutzung umweltgerecht.

MONTAGE

- Bitte befolgen Sie beim Zusammenbauen die einzelnen Arbeitsschritte, die zur besseren Verständlichkeit auch bildlich dargestellt sind.
- Während der Montage ist darauf zu achten, dass sich keine Kinder in unmittelbarer Umgebung aufhalten, da diese versehentlich mitgelieferte Schrauben und andere Kleinteile verschlucken oder inhalieren könnten. Es besteht Lebensgefahr.

REINIGUNG

- Reinigen Sie das Möbelsstück niemals mit Säure, Alkali, aggressive oder Lösungsmittel enthaltende Reinigungsmittel.
- Benutzen Sie stets zuerst ein feuchtes und danach ein trockenes Tuch um die Oberflächen abzuwischen.

EN SAFETY INFORMATION NOTE: Read the entire instruction manual before you start installation and assembly.



ALWAYS OBSERVE THE FOLLOWING SAFETY INSTRUCTIONS.
THE MANUFACTURER IS NOT LIABLE FOR DAMAGES CAUSED BY A FAILURE TO OBSERVE THESE INSTRUCTIONS.

BEFORE USE

- Please let the air out of the product thoroughly before first use.

INTENDED USE

- The item is only intended to be used indoors.
- Avoid direct sunlight and moisture as deforming of the material or colour fading cannot be ruled out.
- Protect the surfaces from sharp objects.
- During use, little children should be supervised by their parents.

DANGER OF SUFFOCATION AND INJURY!

- Do not allow children to play with the packaging. They could suffocate on the film or injure themselves on the outer packaging.
- Do not use the product as a ladder or steps, a safety stand, or gymnastics equipment for children, among other non-intended uses.
- It can tip over and cause serious injury! When using this piece of furniture, make sure that it has a secure footing! Otherwise there is a danger that it may tip over.

RISK OF DAMAGE!

- Assemble the product carefully and follow the assembly instructions.
- The product may be assembled only by qualified personnel.

ENVIRONMENTAL NOTE

- After use, dispose of the packaging and the product in an environmentally friendly manner.

ASSEMBLY

- For assembling please follow the instructions. You can find illustrations for better understanding.
- While assembling the product it should be ensured that no children are in immediate vicinity as they could swallow or inhale included screw or any other small items. There is danger to life.

CLEANING

- Never use acid, alkalis, strong cleaning agent or one that contains a solvent for cleaning.
- First use a wet cloth and after a dry one.

FR CONSIGNES DE SÉCURITÉ ATTENTION : Lisez toute la notice d'utilisation avant de commencer le montage.



VEUILLEZ IMPÉRATIVEMENT OBSERVER LES CONSIGNES DE SÉCURITÉ SUIVANTES.
LE FABRICANT DÉCLINE TOUTE RESPONSABILITÉ POUR LES DOMMAGES CAUSÉS PAR LE NON-RESPECT DE CES CONSIGNES.

AVANT UTILISATION

- Bien aérer avant la première utilisation de l'article.

UTILISATION CONFORME

- Cet article est exclusivement destiné à une utilisation en intérieur.
- N'exposez pas le produit au soleil ou à l'humidité car sinon le matériau pour se rétracter ou la couleur peut passer.
- Évitez de toucher le meuble avec des objets pointus ou tranchants pour ne pas endommager les surfaces.
- Les jeunes enfants doivent toujours être surveillés par leurs parents.

RISQUE D'ÉTOUFFEMENT/DE BLESSURE !

- Ne laissez pas les enfants jouer avec l'emballage. Ils peuvent s'étouffer avec le film ou se blesser avec l'emballage.
- N'utilisez pas l'article comme échelle ou marchepied, bloc de support, appareil de gymnastique pour enfant etc. Il peut basculer et entraîner des blessures.
- Lors de l'utilisation du meuble, veillez à une bonne stabilité ! Sinon, il risque de basculer !

RISQUE DE DÉGRADATION !

- Lors du montage de l'article, procédez avec prudence et conformez-vous à la notice de montage.
- L'article doit être uniquement monté par des personnes habilitées.

CONSIGNE ENVIRONNEMENTALE

- Après utilisation, mettez l'emballage et le produit au rebut de manière écologique.

MONTAGE

- Pour l'assemblage, veuillez respecter les différentes étapes de travail qui sont également illustrées pour une meilleure compréhension.
- Pendant le montage, il faut veiller à ce qu'aucun enfant ne soit à proximité car ils peuvent avaler ou inhaler par erreur les vis et autres pièces fournies. Il existe un danger de mort.

NETTOYAGE

- Ne nettoyez jamais le meuble avec des produits nettoyants contenant de l'acide, des produits alcalins, des produits agressifs ou des solvants.
- Commencez toujours par utiliser un chiffon humide puis un chiffon sec pour essuyer les surfaces.



ES INDISPENSABLE QUE TENGA EN CUENTA LAS SIGUIENTES RECOMENDACIONES DE SEGURIDAD. EL FABRICANTE NO SE HACE RESPONSABLE DE LOS DAÑOS QUE SE ORIGINEN POR INOBSERVANCIA DE LAS MISMAS.

► **RECOMENDACIONES DE SEGURIDAD ANTES DEL USO**

- Antes del primer uso, ventile bien el artículo.

► **USO CONFORME A LAS NORMAS**

- Este artículo solo es apto para áreas interiores.
- No exponga el producto al sol o a la humedad; puesto que en tal caso hay riesgo de deformación del material o de decoloración.
- Para no dañar la superficie, evite tocar la pieza de mobiliario con objetos puntiagudos o afilados.
- Durante el uso, los niños pequeños siempre deberán encontrarse bajo vigilancia de sus padres.

► **RIESGO DE ASFIXIA/LESIONES!**

- No deje que los niños jueguen con el embalaje. Podrían asfixiarse con la lámina o resultar heridos con el embalaje.
- No utilice el artículo para subirse encima, como soporte de apoyo, aparato de ejercicios físicos para niños, o para usos similares. Podría volcar y provocar lesiones.
- ¡Cuando vaya a utilizar la pieza de mueble, asegúrese de que está bien asentada! En caso contrario, existe riesgo de vuelco.

► **RIESGO DE DAÑOS!**

- Cuando vaya a montar el artículo, proceda cuidadosamente y atégase a las instrucciones de montaje.
- El artículo solo pueden montarlo profesionales.

► **INDICACIONES MEDIOAMBIENTALES**

Una vez utilizados, deshágase del embalaje y del producto de forma respetuosa con el medio ambiente.

► **MONTAJE**

- Durante el montaje, siga uno por uno los pasos descritos que, para mejor comprensión, también se representan con imágenes.
- Durante el montaje, preste atención a que no haya niños en las proximidades inmediatas, puesto que estos podrían tragar o inhalar por descuido tornillos incluidos en el volumen de suministro. Ello supone un peligro mortal.

► **LIMPIEZA**

- Nunca limpie el mueble con productos de limpieza ácidos, alcalinos, agresivos o que contengan disolventes.
- Utilice siempre primero un paño húmedo y después un paño seco para limpiar las superficies.



SI PREGA DI OSSERVARE LE SEGUENTI ISTRUZIONI IN MATERIA DI SICUREZZA. IL PRODUTTORE NON SI ASSUME ALCUNA RESPONSABILITÀ PER DANNI RICONDUCCIBILI ALLA NON OSSERVANZA DI QUESTE ISTRUZIONI.

► **PRIMA DEL PRIMO UTILIZZO**

- Prima del primo utilizzo, far arieggiare bene l'articolo.

► **USO CONFORME**

- Questo articolo è destinato esclusivamente all'utilizzo in ambienti interni.
- Non esporre l'articolo al sole e all'umidità dal momento che non è possibile escludere eventuali distorsioni dei materiali o lo sbiadimento dei colori.
- Evitare di entrare in contatto con il dispositivo con oggetti appuntiti o taglienti per prevenire danni sulla superficie.
- Bambini piccoli dovrebbero essere sempre sotto la supervisione dei genitori.

► **RISCHIO DI SOFFOCAMENTO E LESIONI**

- Non permettete ai bambini di giocare con la confezione dell'articolo. Potrebbero soffocare a causa della pellicola oppure ferirsi con l'imballaggio esterno.
- Non utilizzare l'articolo come scalandrino o sgabello, cavalletto, attrezzo ginnico o simili. Potrebbe ribaltarsi e causare lesioni.
- Durante l'uso, si prega di prestare particolare attenzione all'effettiva stabilità del dispositivo! In caso contrario sussiste il pericolo di ribaltamento!

► **PERICOLO DI DANNI!**

- Procedere con attenzione durante l'assemblaggio dell'articolo e seguire diligentemente le istruzioni di montaggio.
- L'articolo deve essere montato da persone qualificate.

► **NOTE AMBIENTALI**

Una volta disballato e dismesso l'articolo, smaltire l'imballo e il dispositivo stesso in maniera ecologicamente sostenibile.

► **MONTAGGIO**

- Durante l'assemblaggio, seguire i singoli passaggi illustrati anche con immagini grafiche per una migliore comprensione.
- Assicurarsi che non ci siano bambini nelle immediate vicinanze durante il montaggio dal momento che questi potrebbero ingoiare o inalare inavvertitamente viti e altre minuterie contenute nella fornitura. Sussiste il pericolo di morte.

► **PULIZIA**

- Non pulire mai il dispositivo con detergenti contenenti acidi, alcali o solventi.
- Passare semplicemente prima un panno umido, quindi un panno asciutto sulle superfici per pulirle.

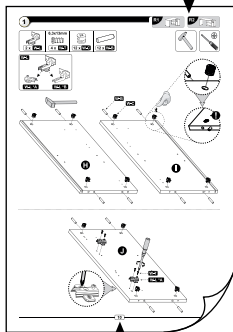

10 - 22

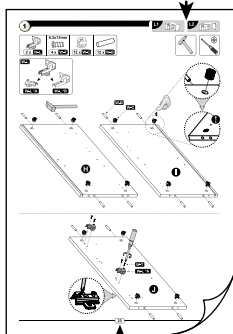
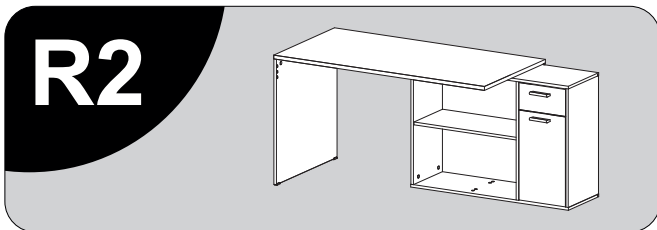
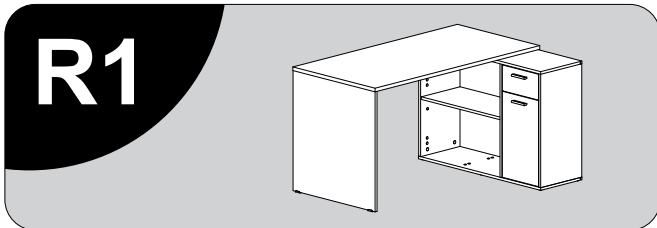

23 - 35

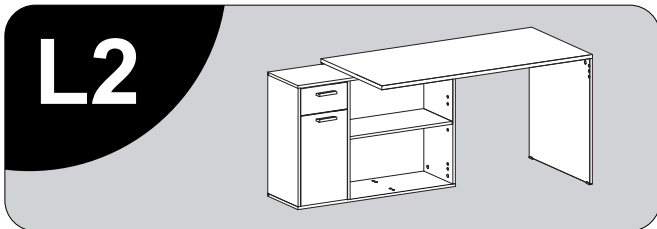
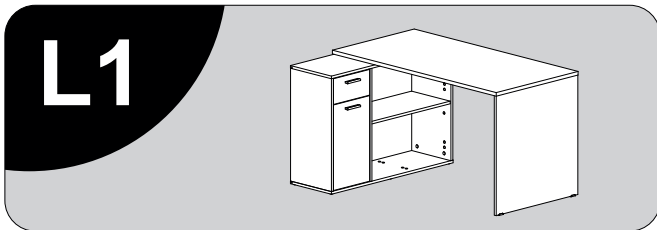

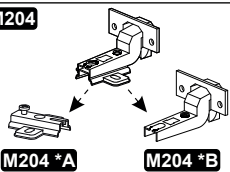
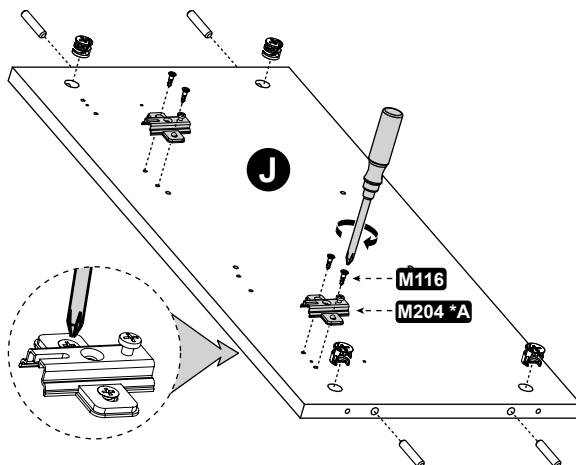
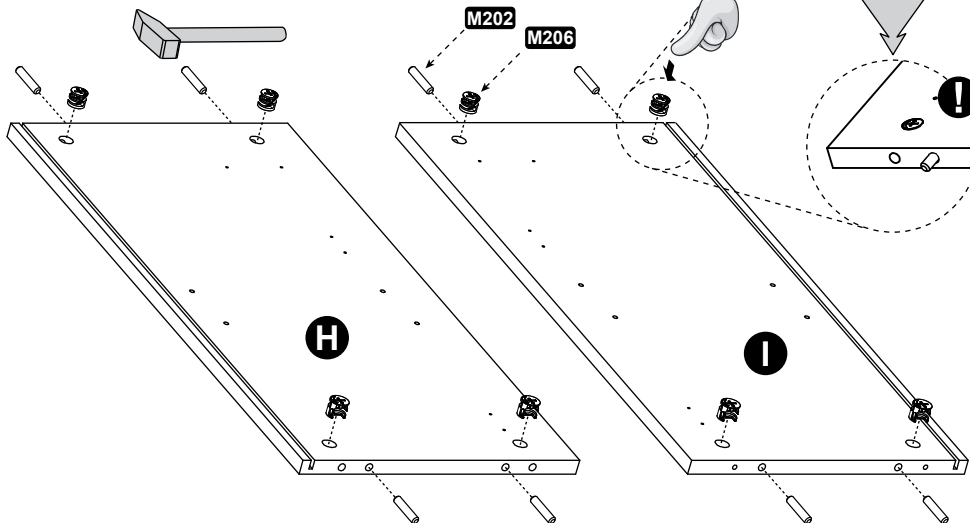
1**R1****R2****2 x M204****4 x M116****12 x M206****12 x M202****M204****M204 *A****M204 *B**

2

R1



R2

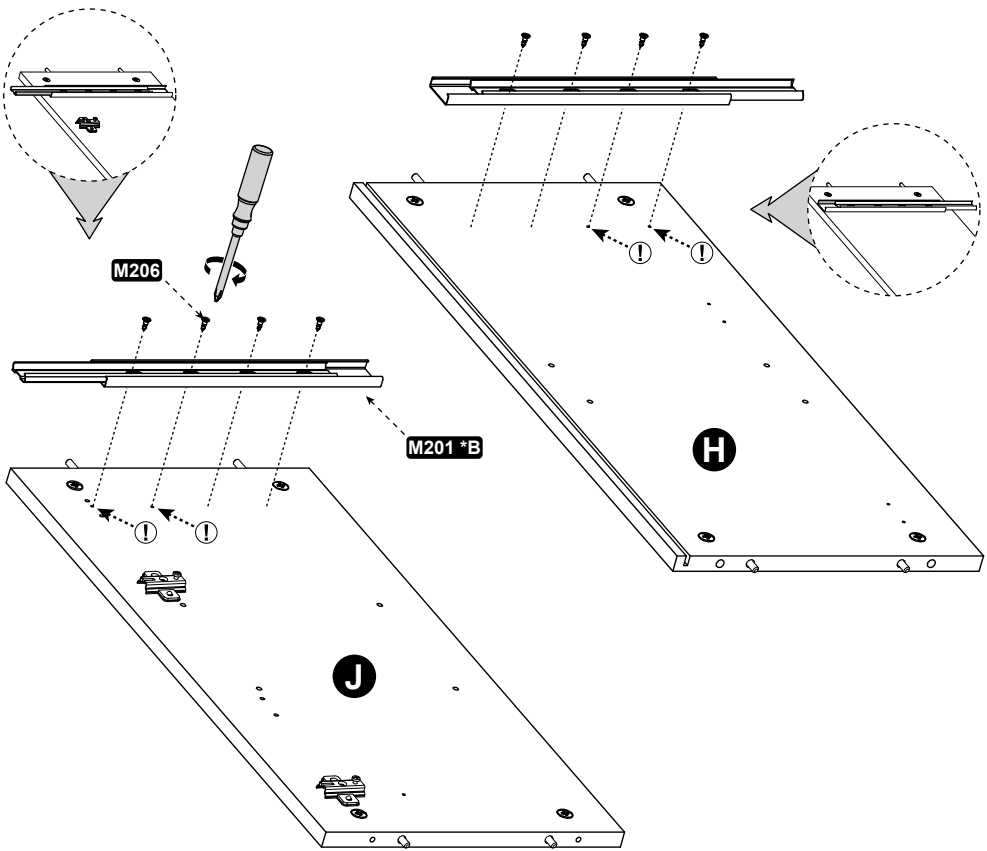
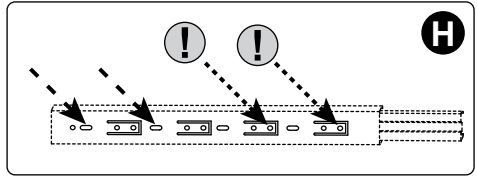
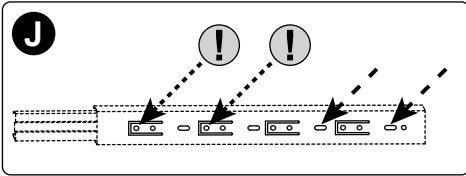
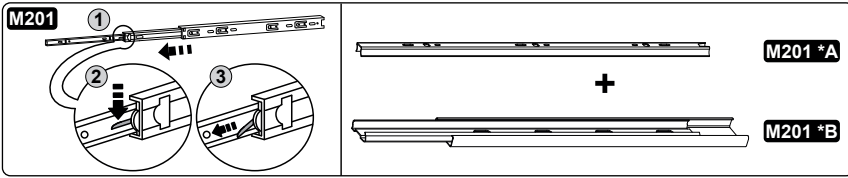
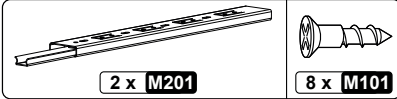

3

R1



R2

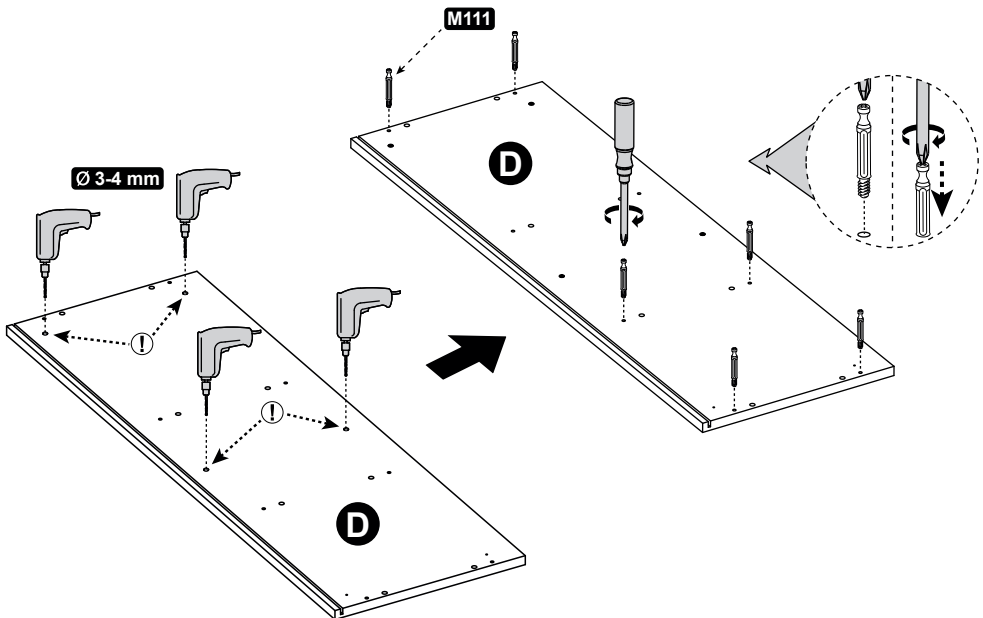
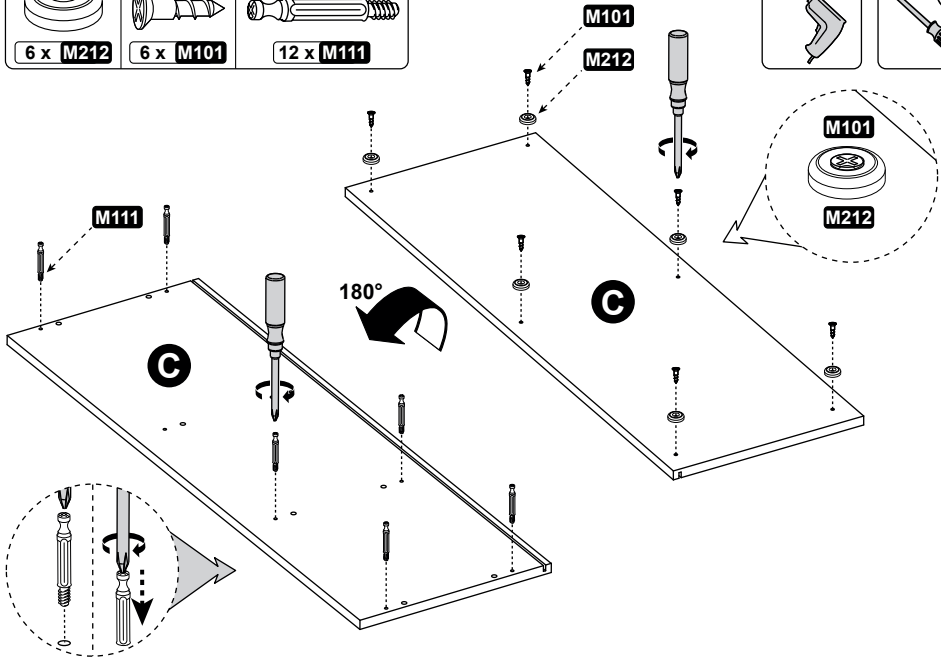
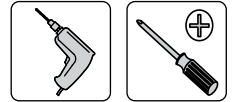
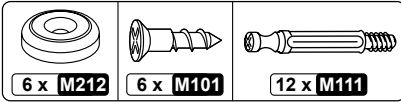

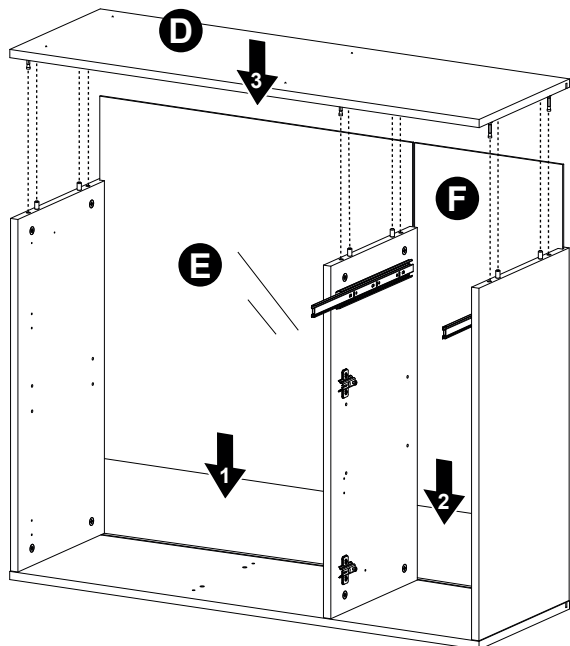
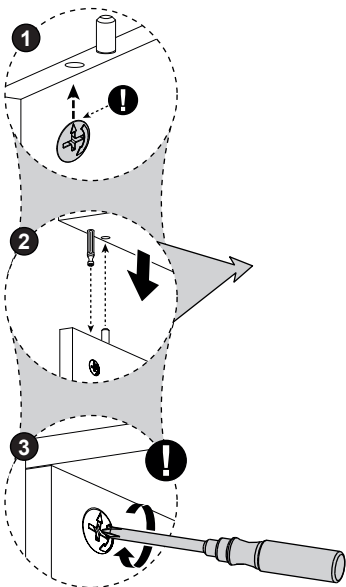
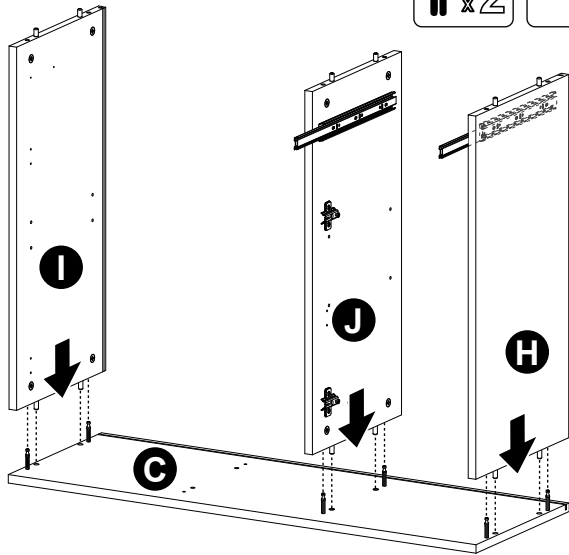
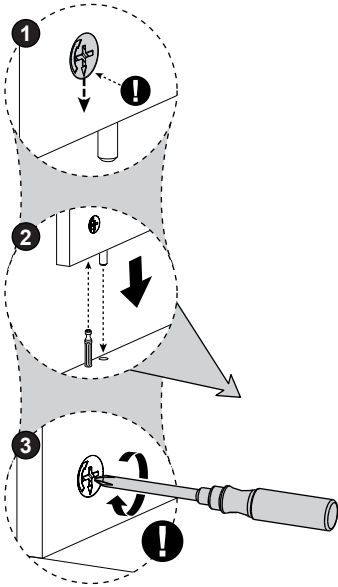

5

R1



R2

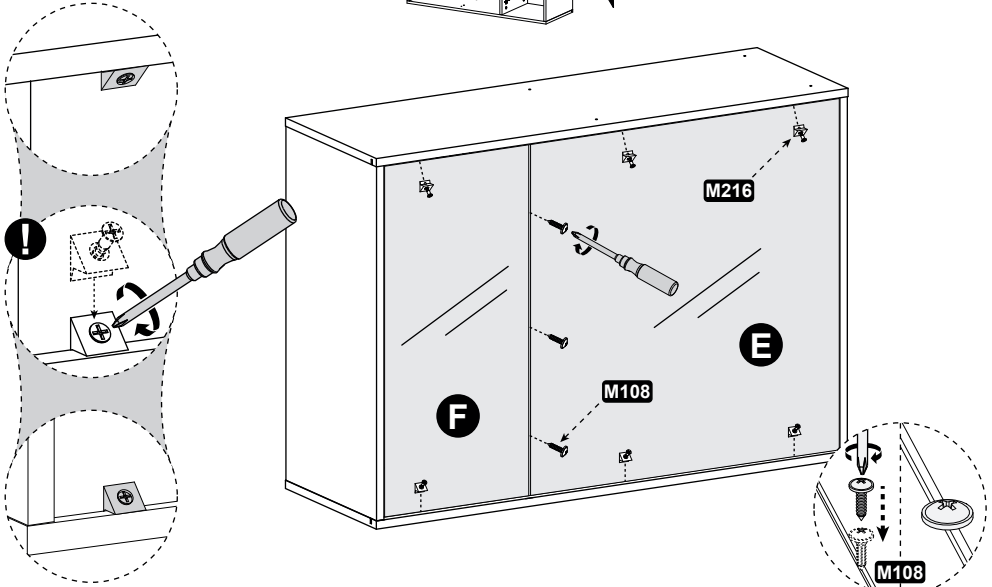
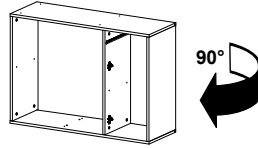
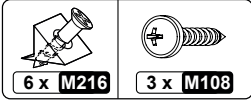

6

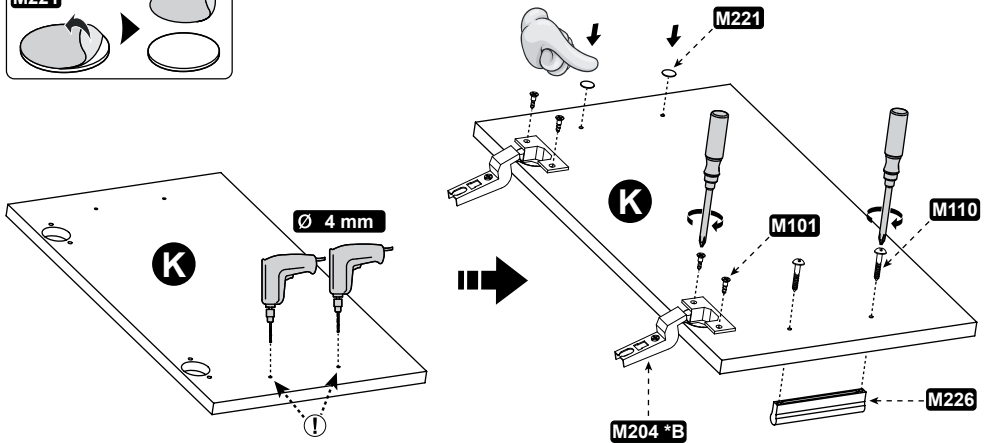
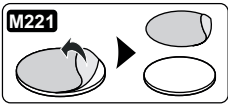
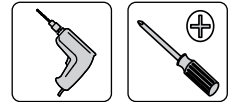
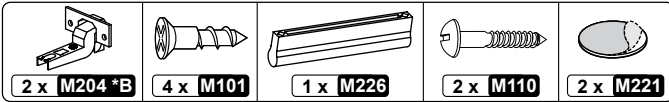

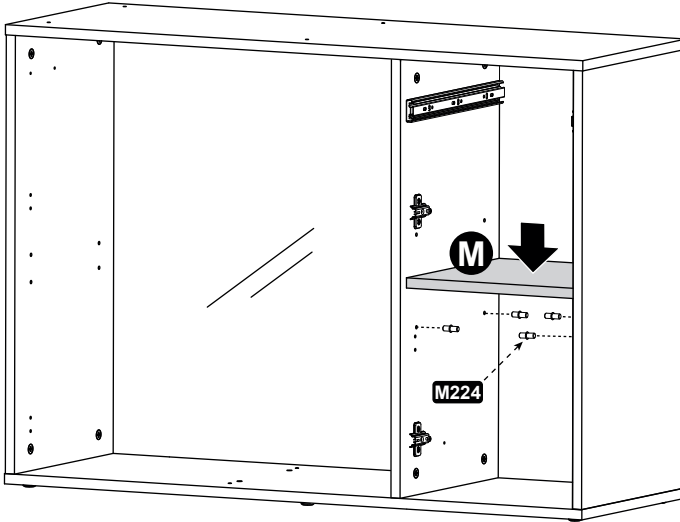
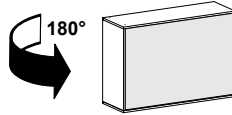
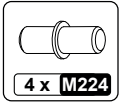
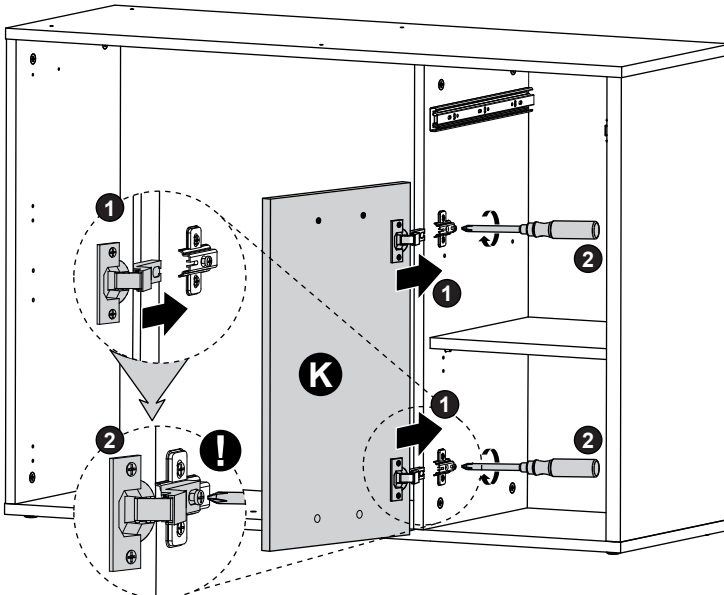
7**R1****R2****8**

9

R1



R2



2 x M202

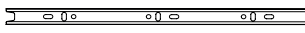

2 x M201 *B



6 x M101



4 x M206

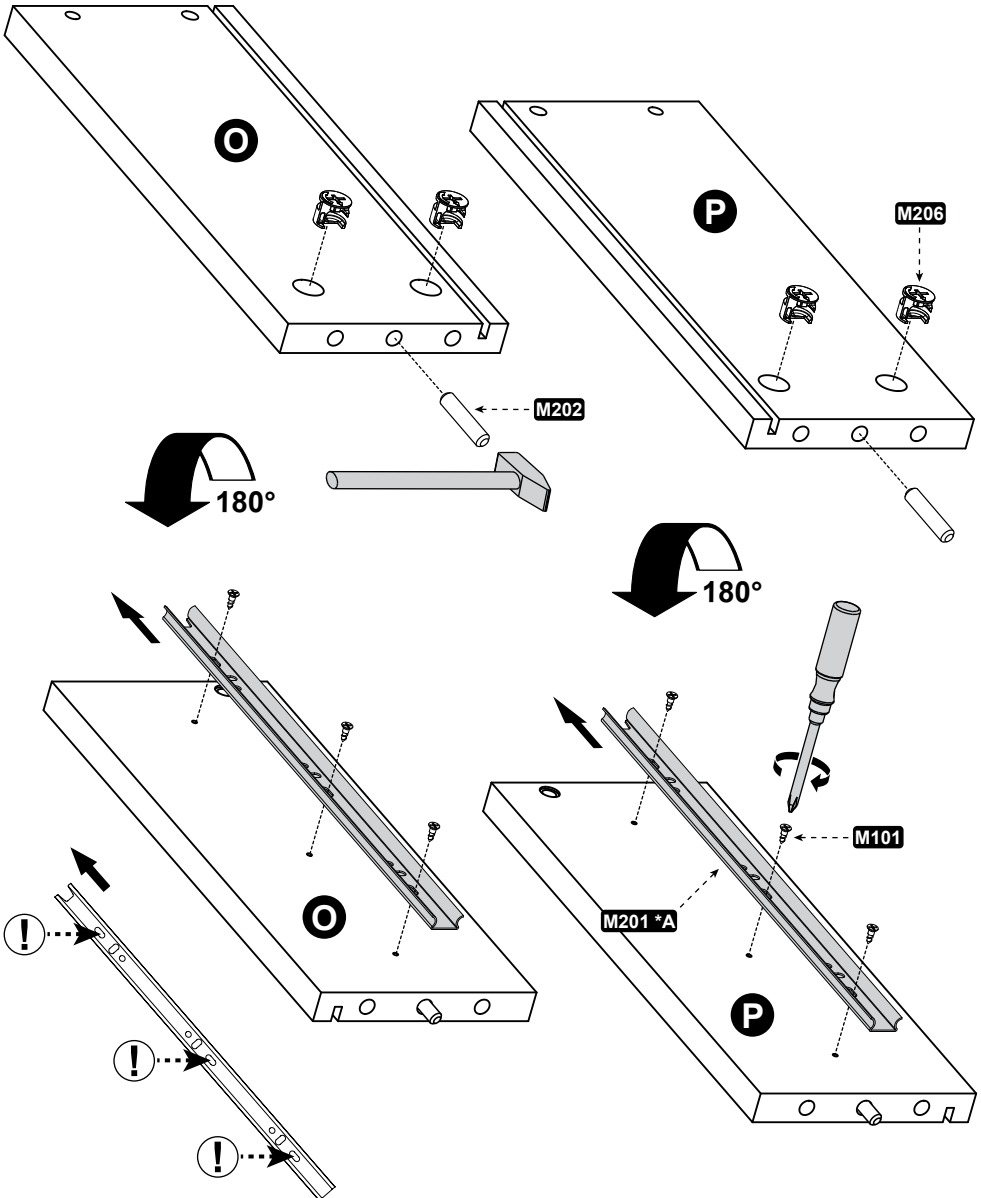

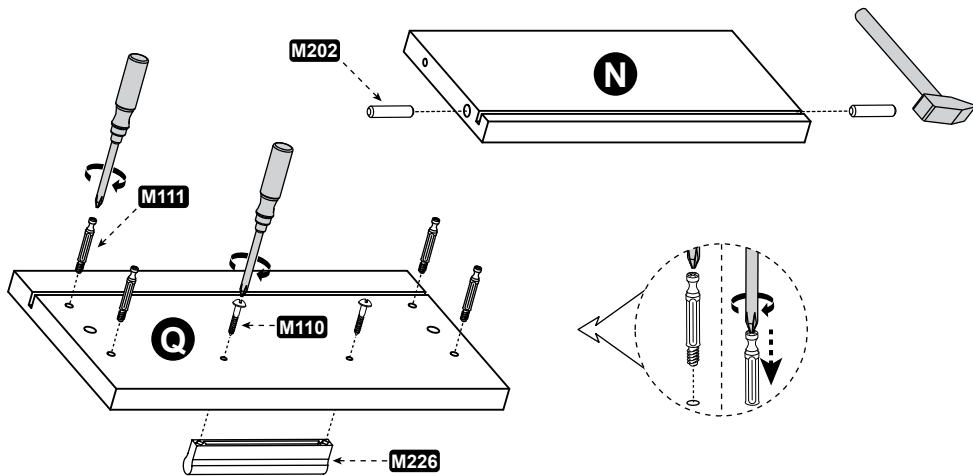
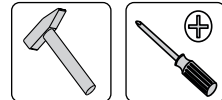
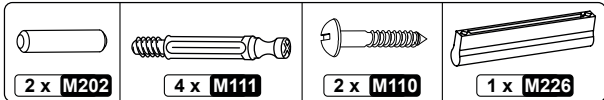
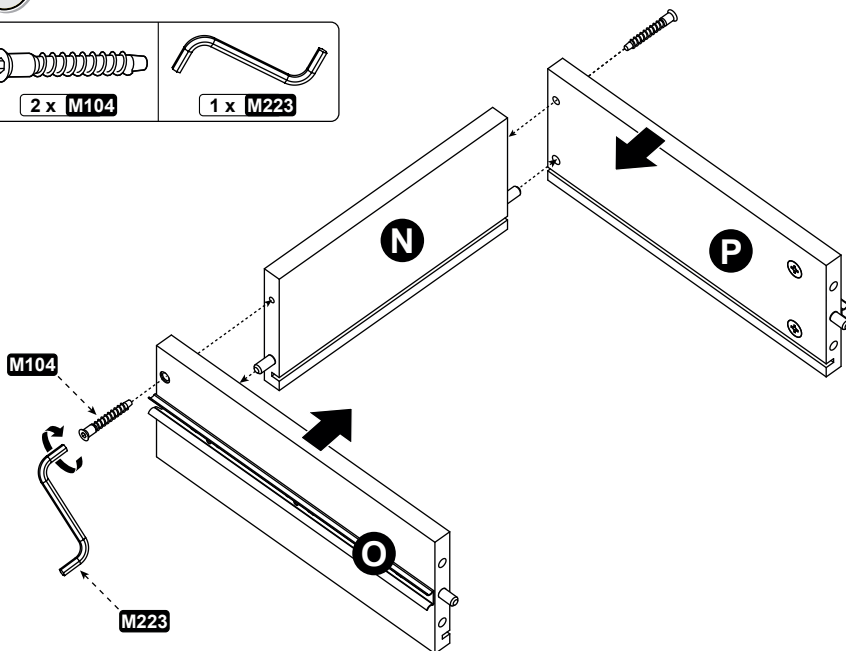
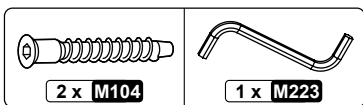
10**R1****R2****11**

12

R1



R2

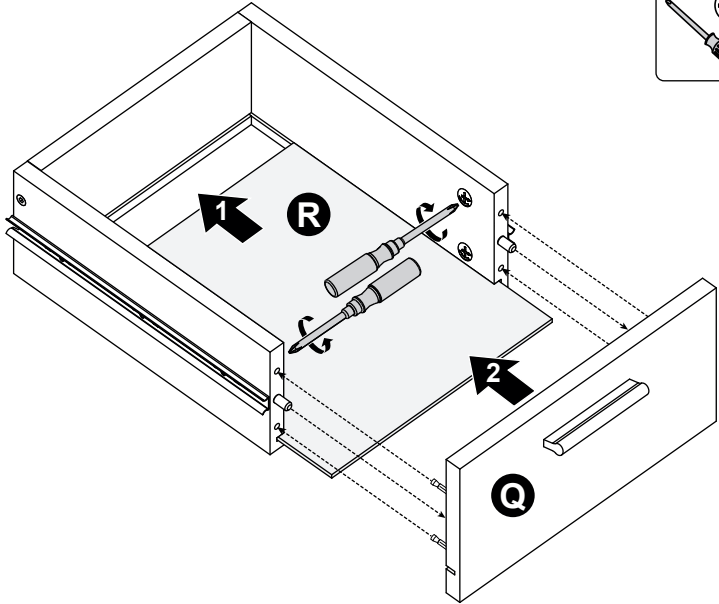
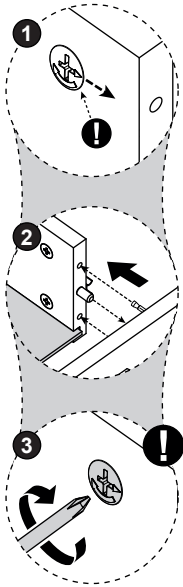

13

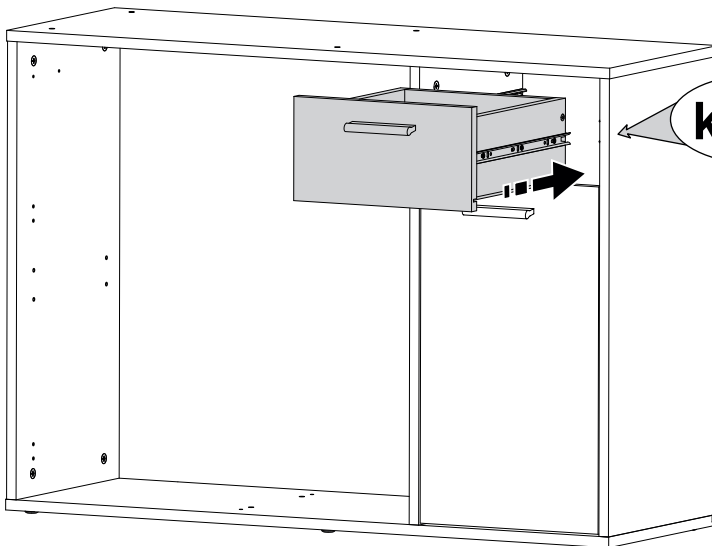

14

R1



R2

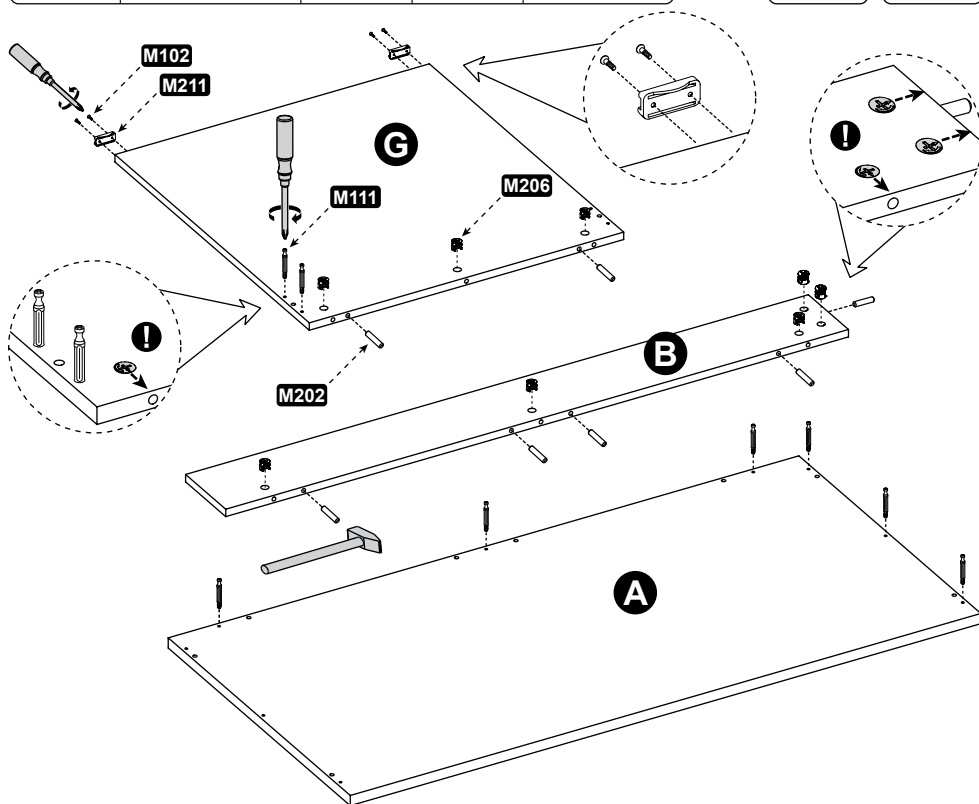
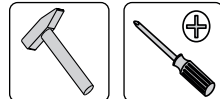
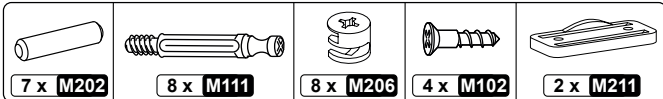

15

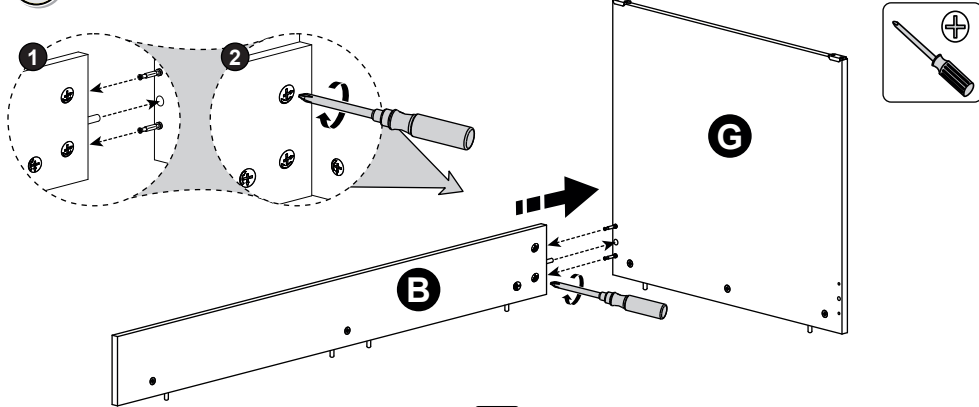

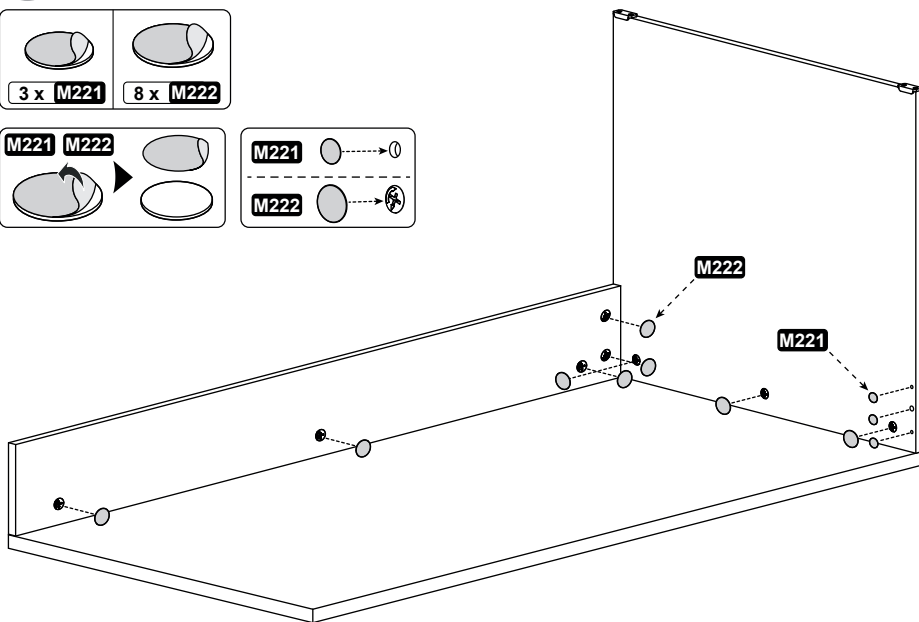
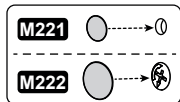
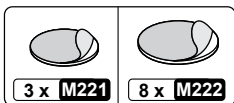
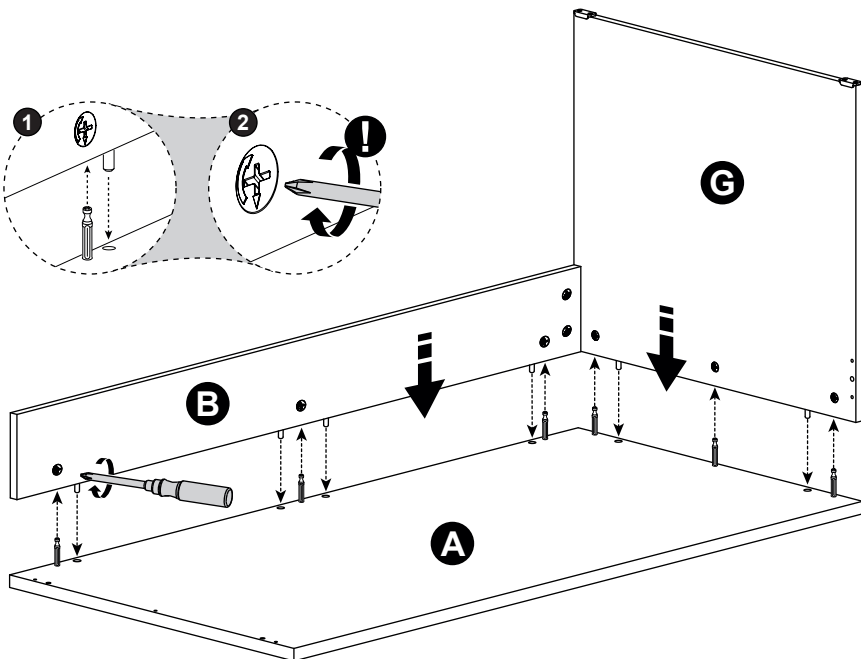
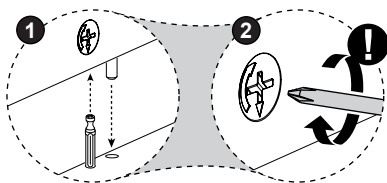

18

R1



R2

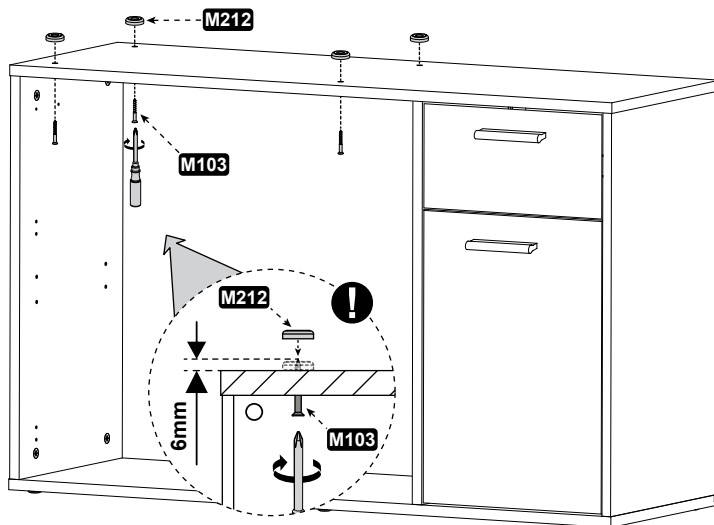
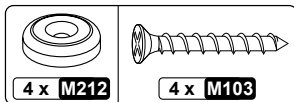

19

R1

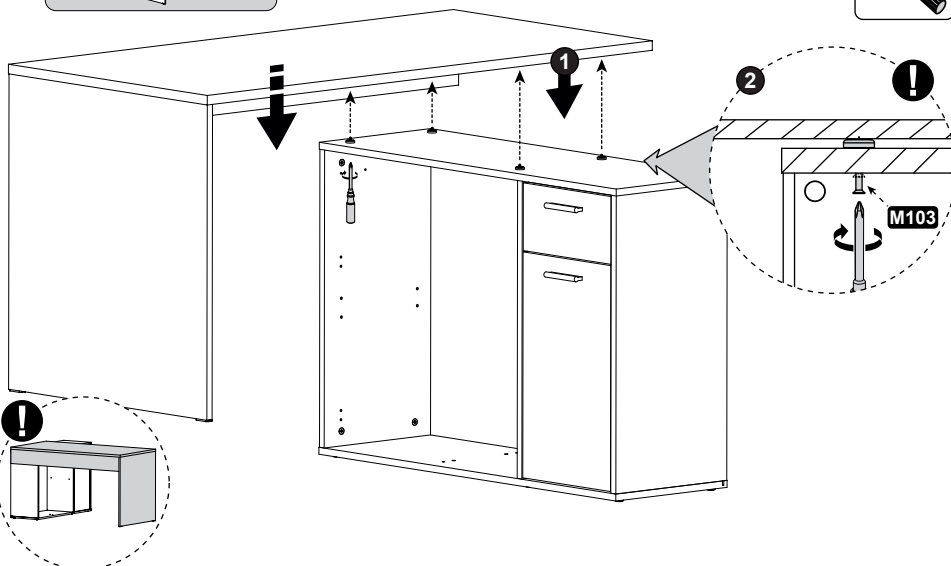
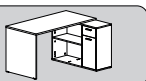

20

R1



R2



R2

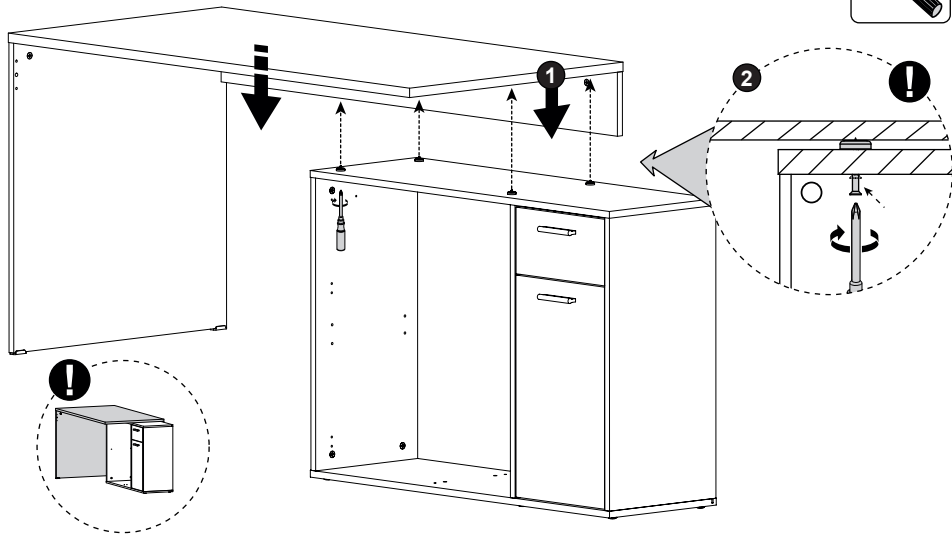
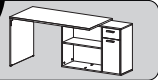

21

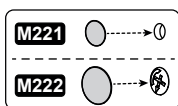
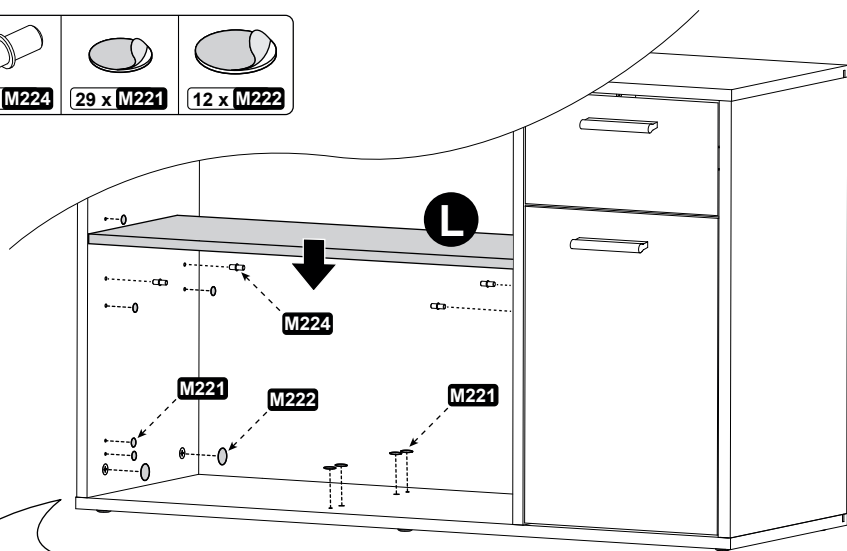

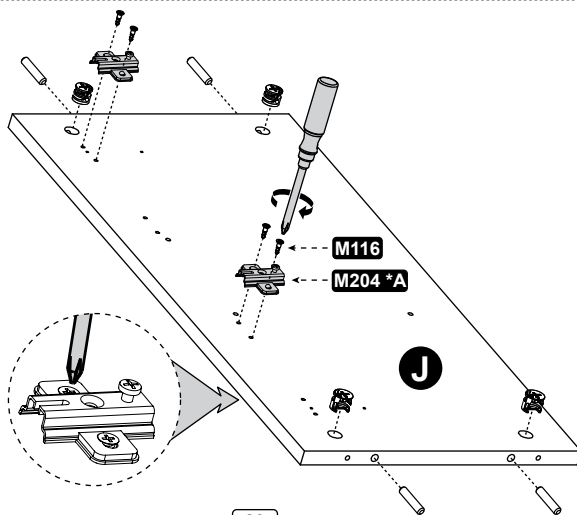
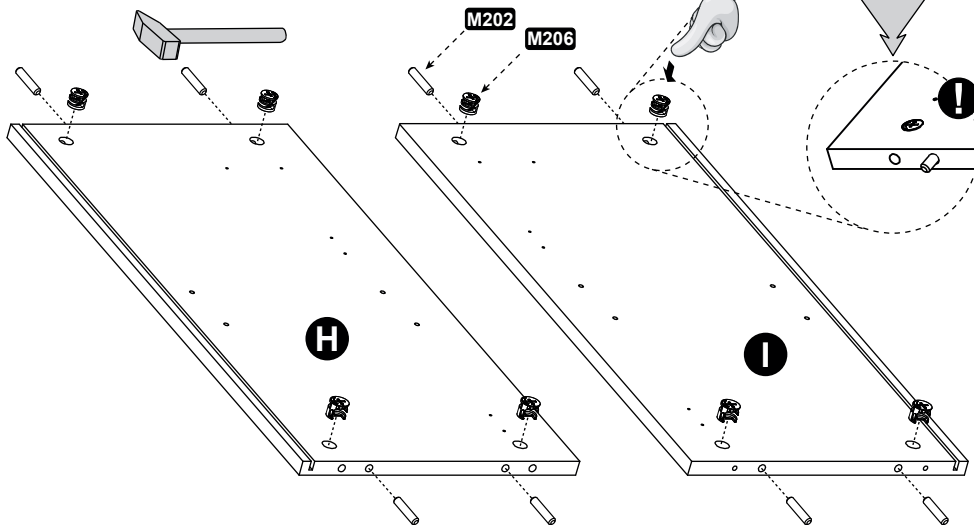
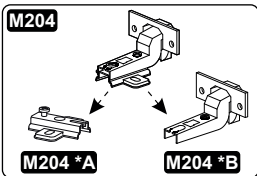
1**L1****L2****2 x M204****4 x M116****12 x M206****12 x M202**

2

L1



L2

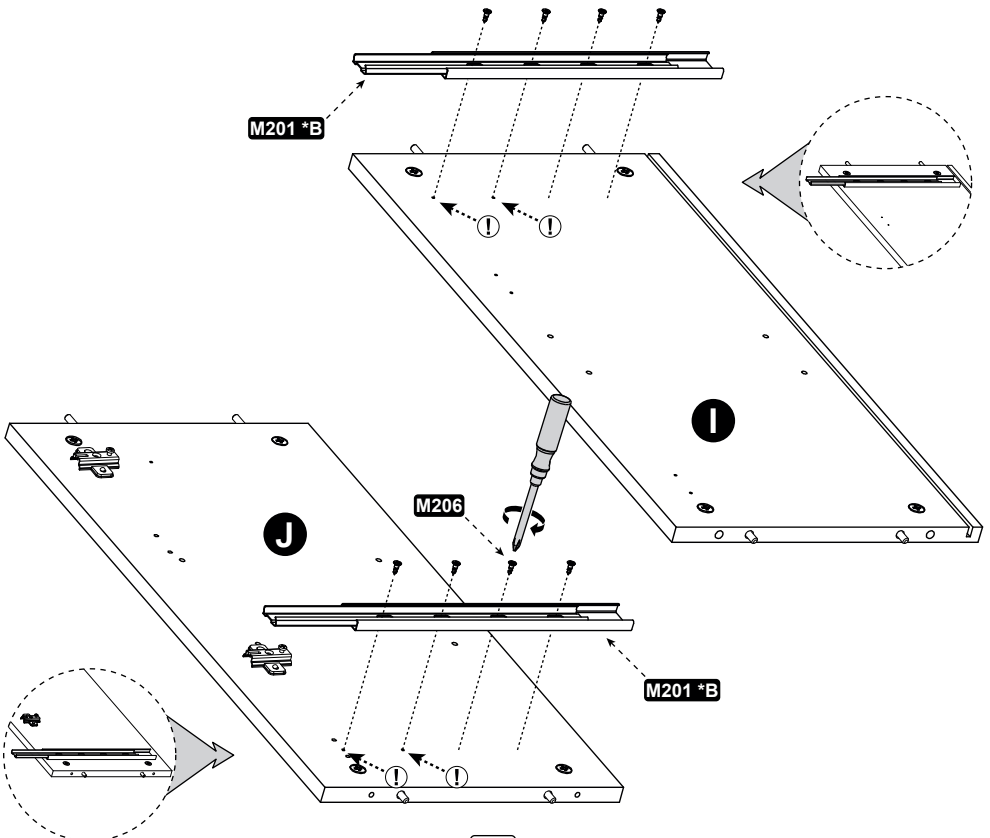
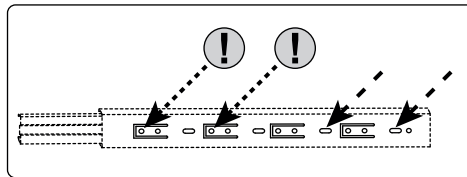
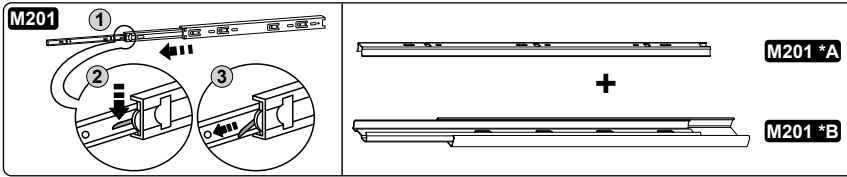
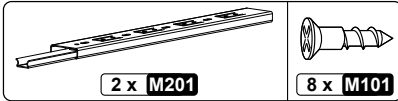

3

L1



L2

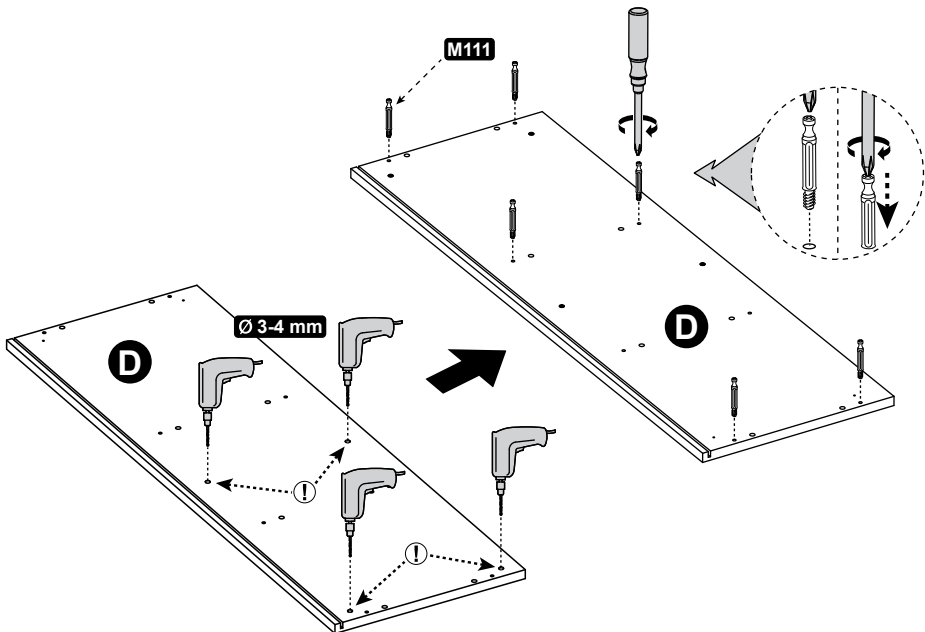
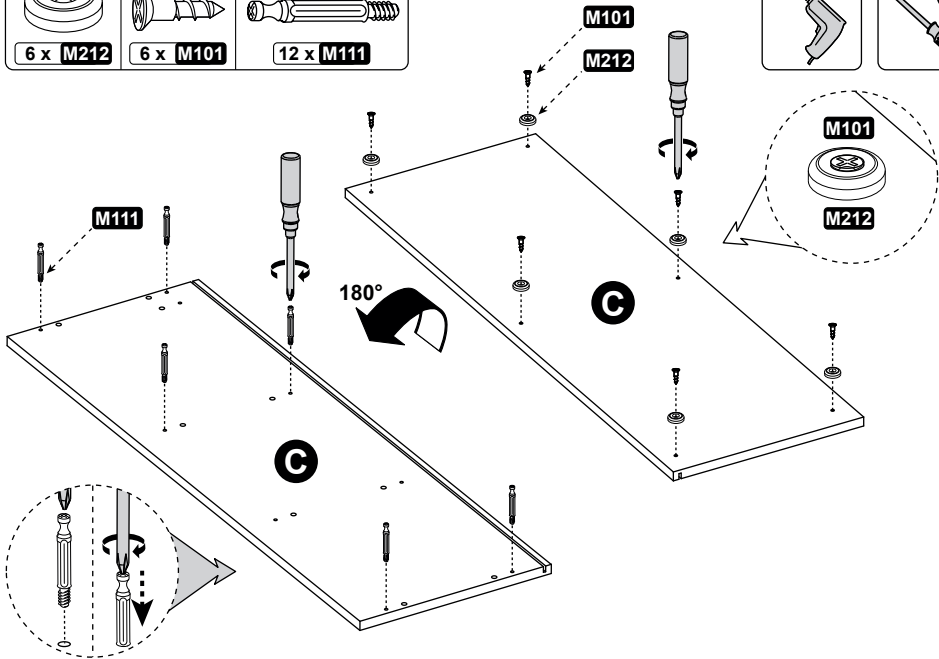
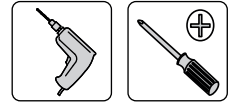
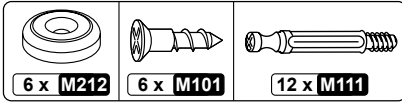

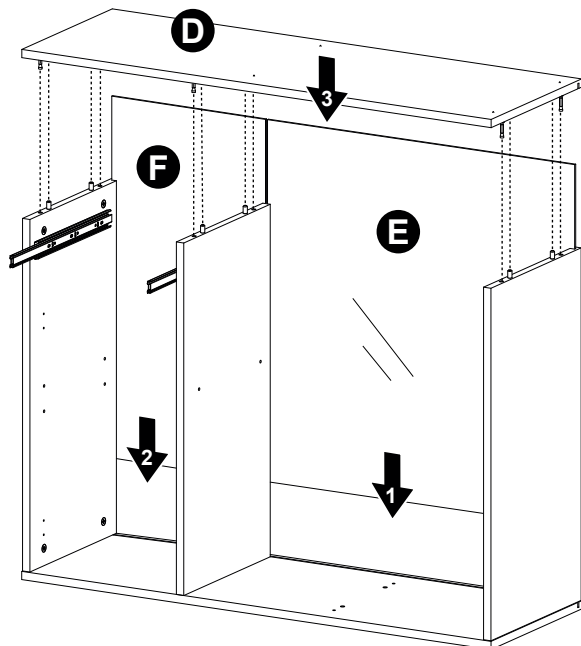
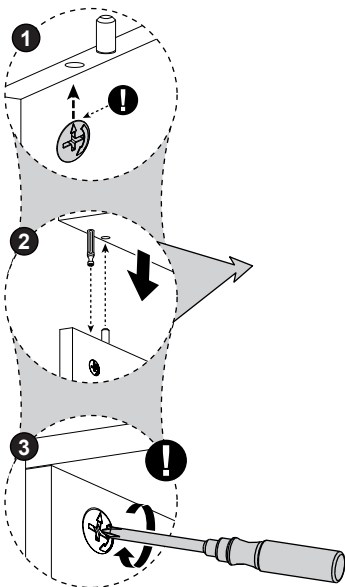
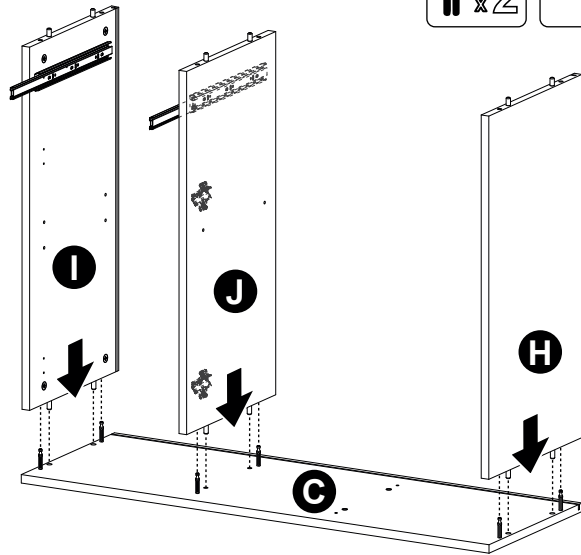
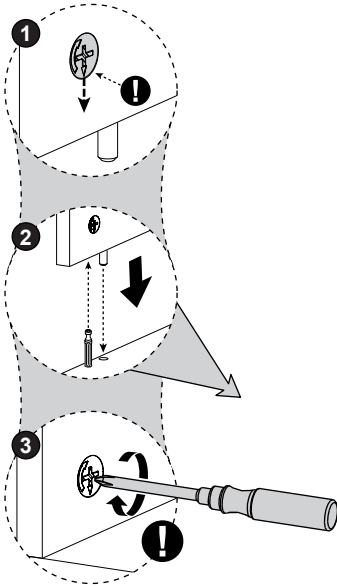

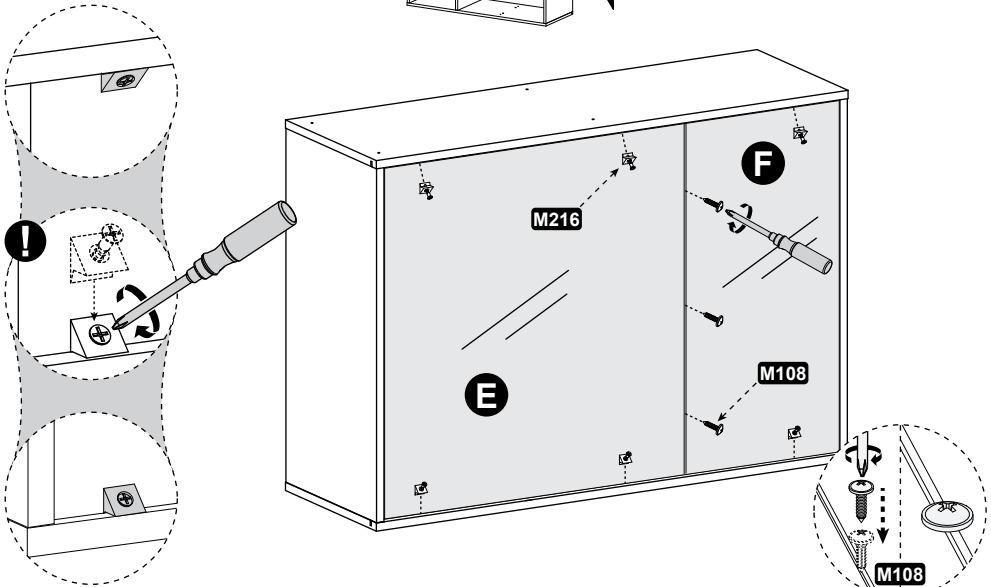
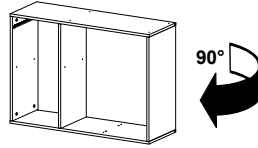
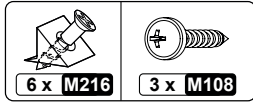
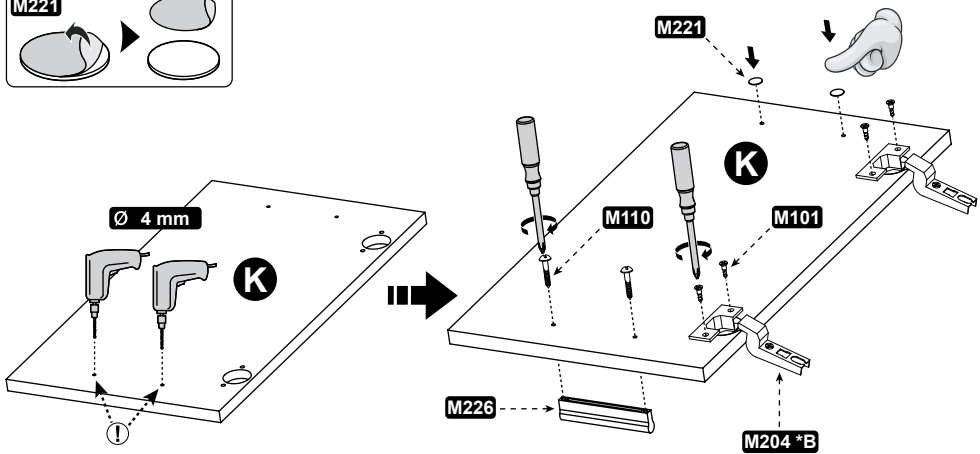
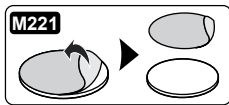
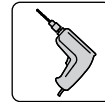
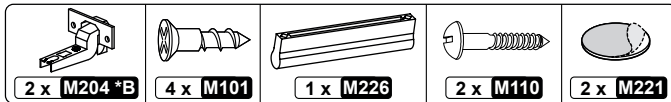
5**L1****L2****6**

7

L1



L2

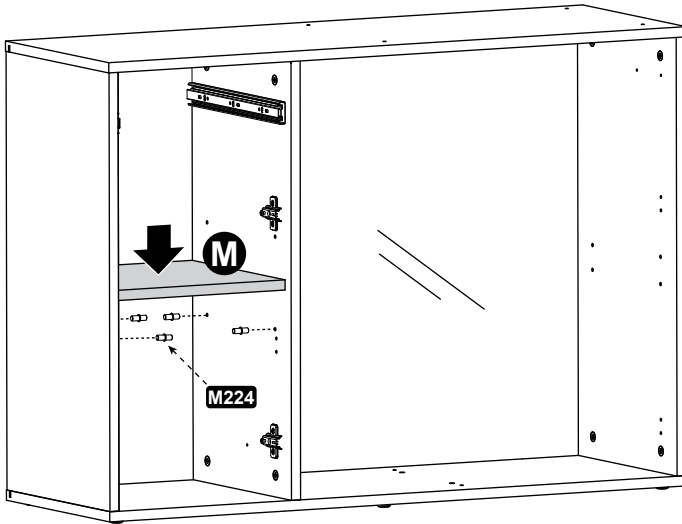
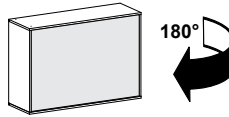
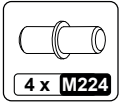

8

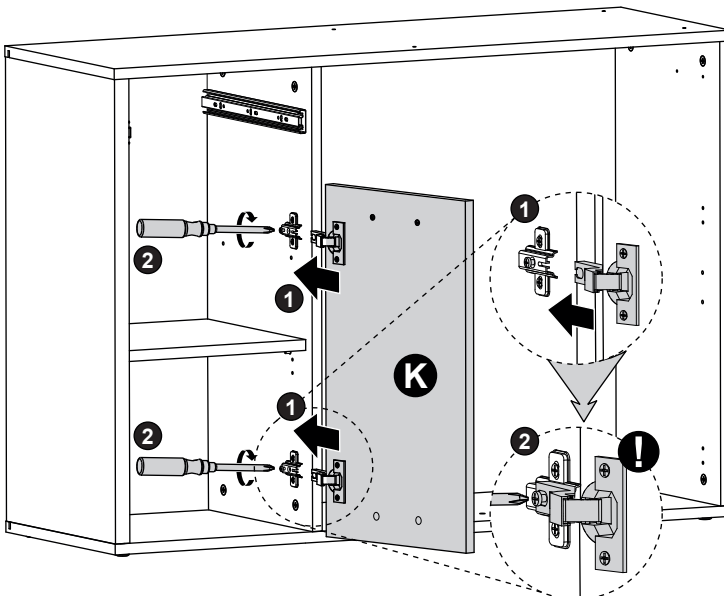



2 x M202	2 x M201 *B	6 x M101	4 x M206

--	--

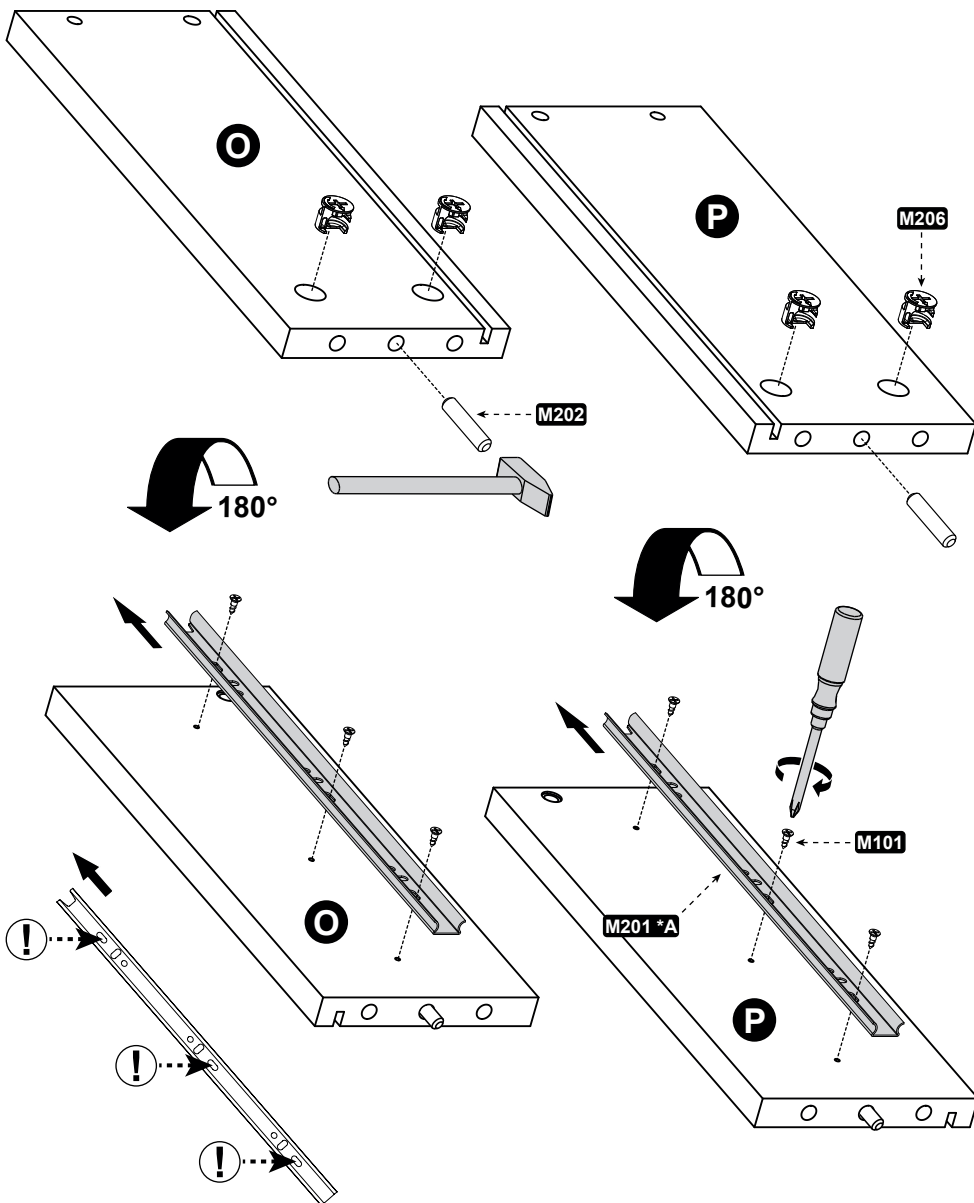

10

L1



L2

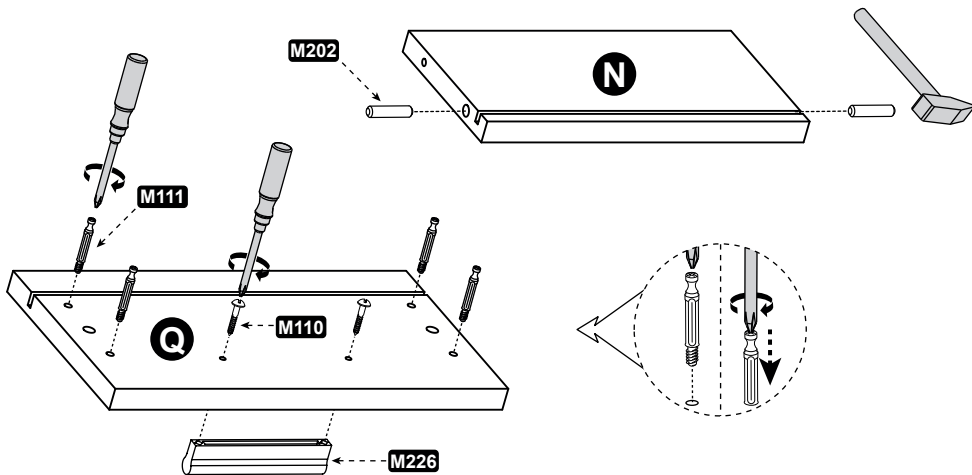
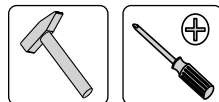
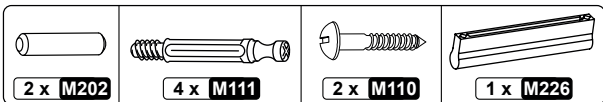

11

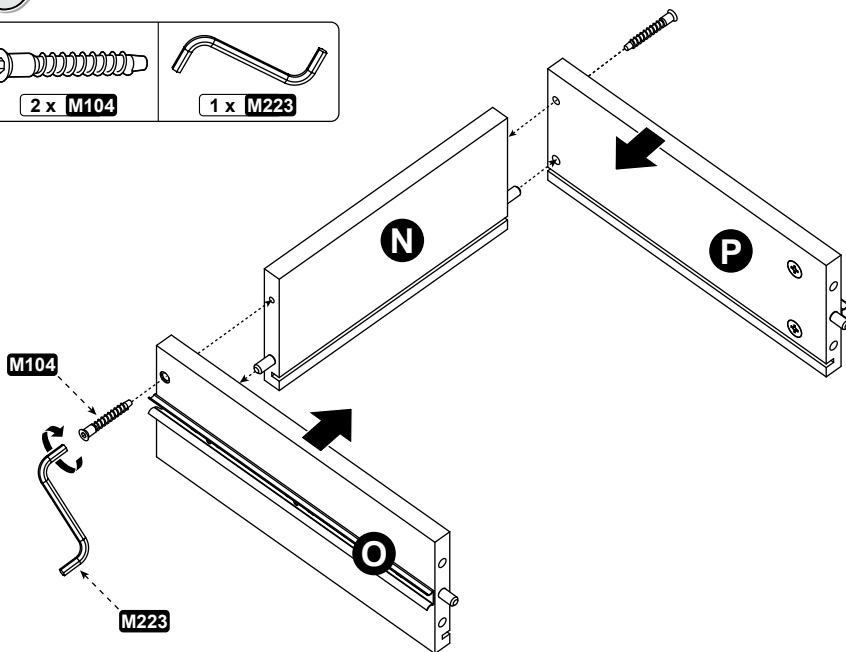
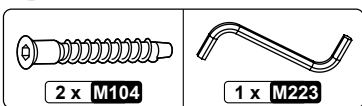

12

L1



L2

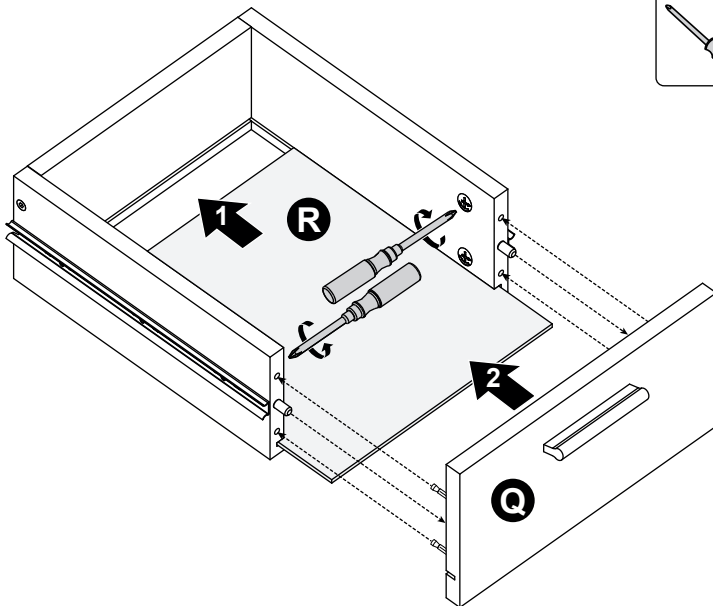
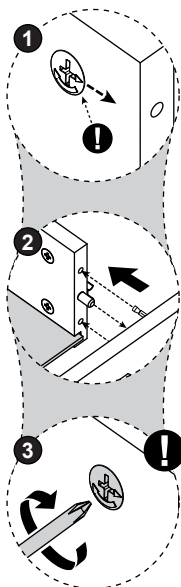

13

klick!

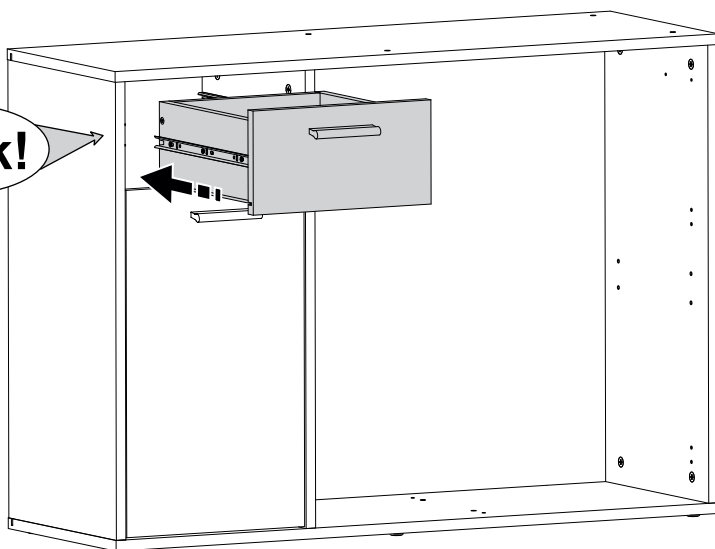

14

L1



L2

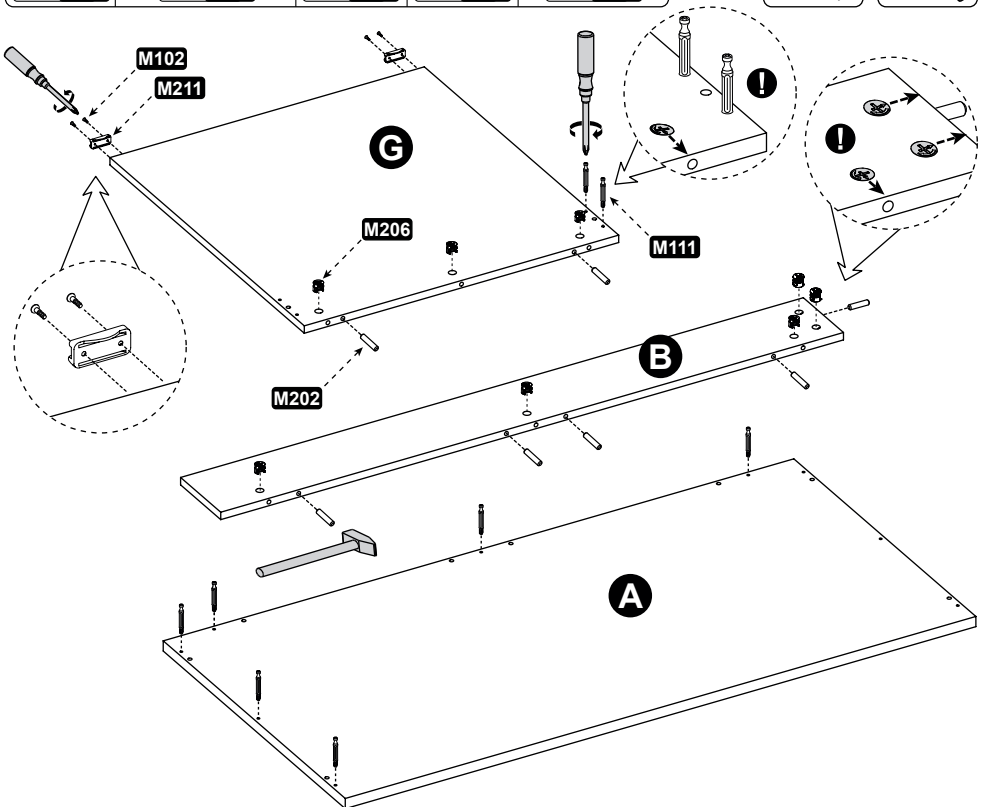
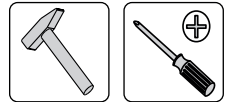
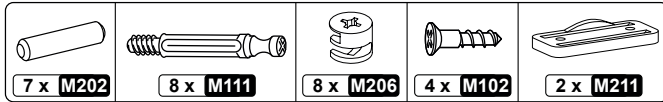

15

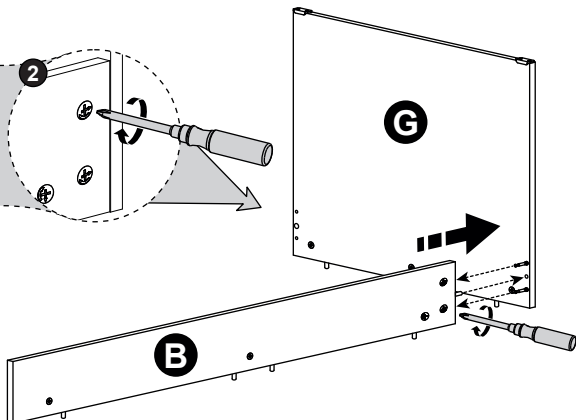
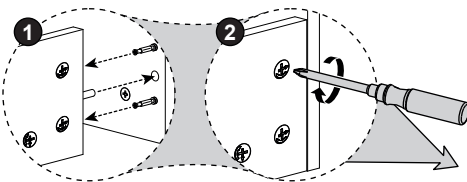

16

L1



L2

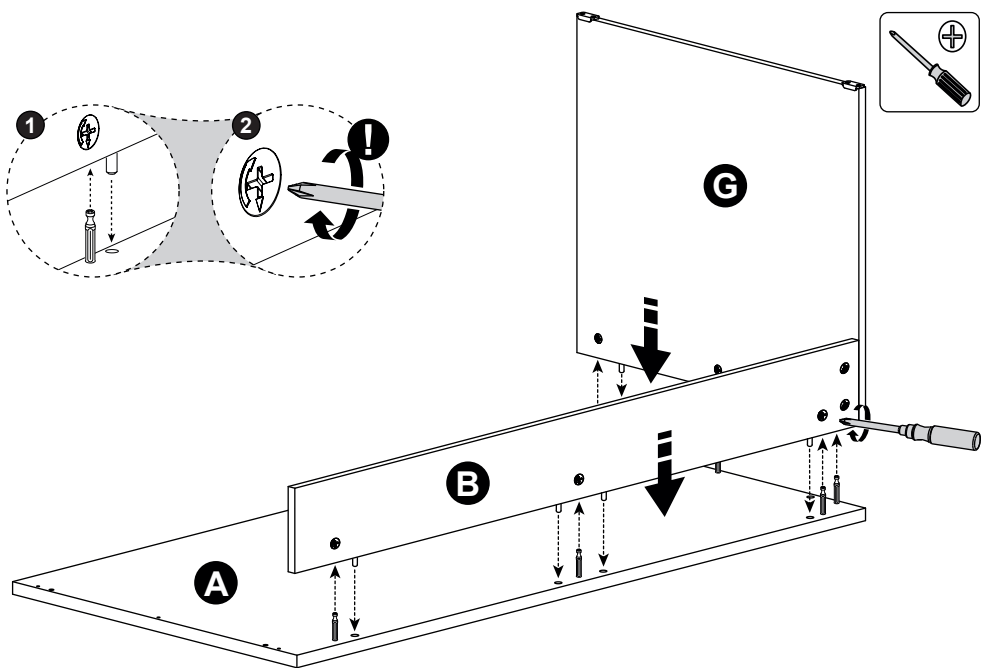
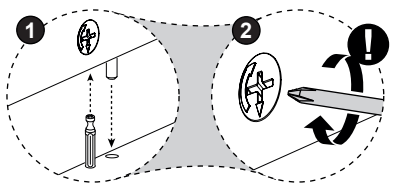

17

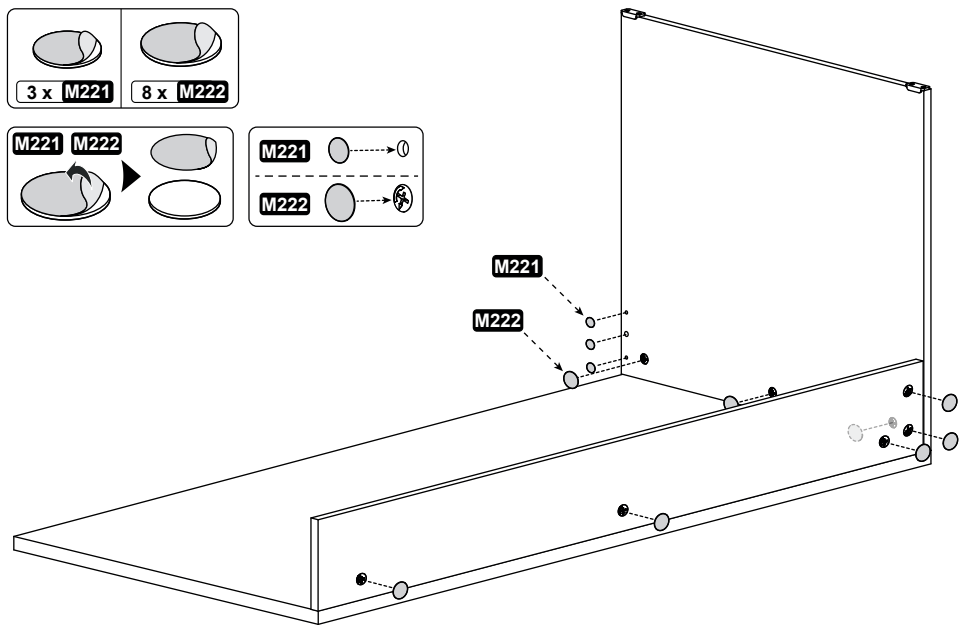
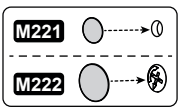
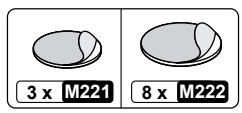

18

L1



L2

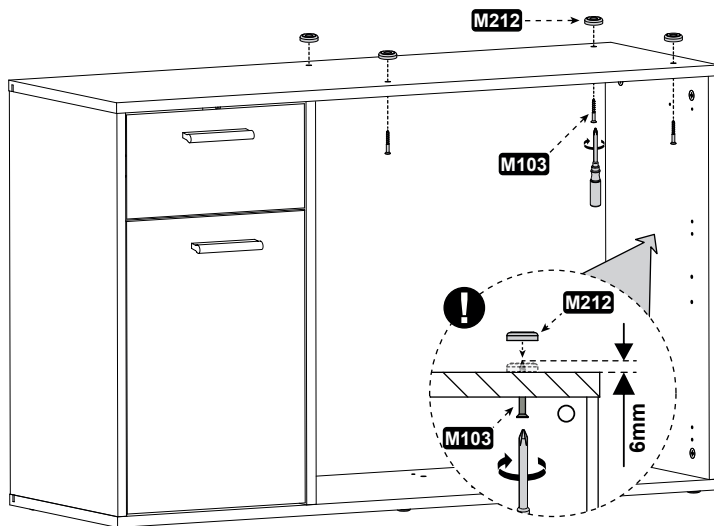
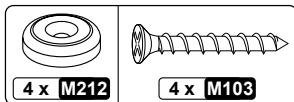

19

L1

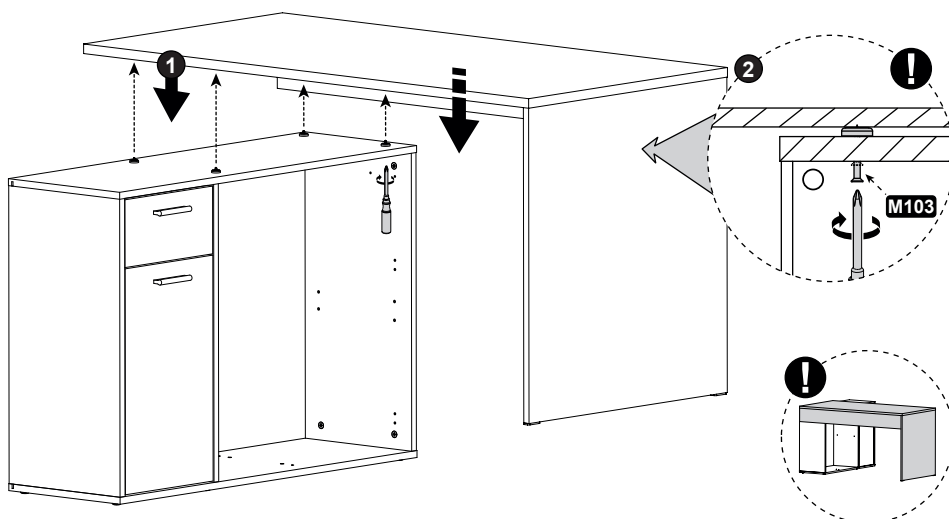
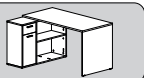

20

L1



L2



L2

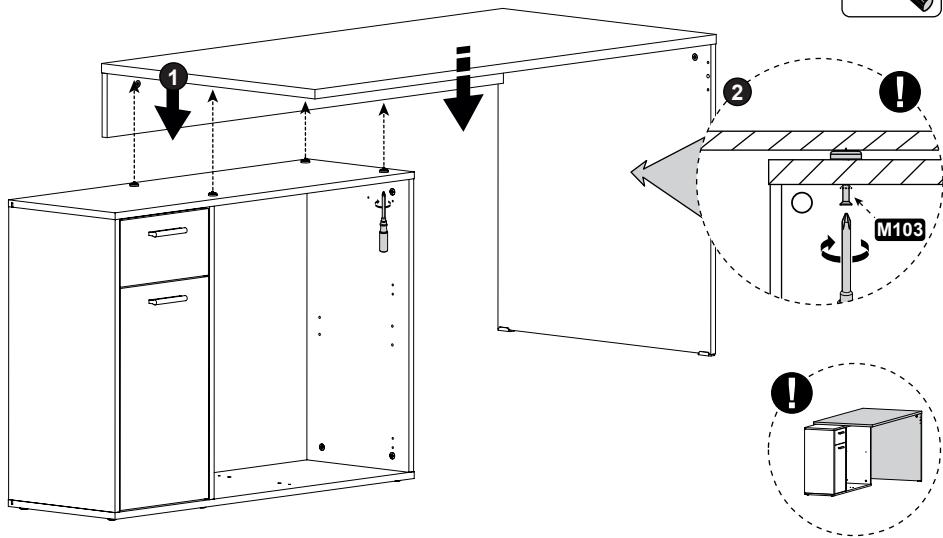
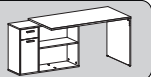

21

